

EUROPEAN DISTRIBUTORS

AGORA TECHNIQUE S.A.R.L.
Parc Volta 3 Rue Parmentier
F - 94140 Alfortville
Tel. +33 145 18 43 70
Fax.. +33 145 18 43 71
E-mail: agora@agora-technique.com

DRECKSHAGE
August Dreckshage GmbH & Co.KG
Walter-Werning-Straße 7 D
33699 Bielefeld
Tel. +49 521 925 92 89
Fax. +49 521 92 59 0
E-mail: zentrale@dreckschage.de

ZARIAN
BEWEGUNGSSYSTEME GmbH
Bayreuther Str.5
95615 Marktredwitz
Tel.+49 923 16 03-851
Fax.+49 923 16 03-859
E-mail: info@zarian.scherdel.de

IBALTEC SISTEMAS S.L.
C/Josep Soler 74-76 Bjs
08310 ARGENTONA
(BARCELONA)
Tel. +34 937 56 11 53
Fax. +34 937 97 40 34
E-mail: info@ibaltec.com

09/2002 EDITION
This publication cancels any
previous one.

Due to the constant progress
of our research, we reserve
the right to modify drawings of
features without notice.

No part of this catalogue may
be reproduced without written
permission express from the
copyright owner .

All rights reserved.

This catalogue has been
accurately checked before
publishing.

We disclaim all responsibility in
case of errors and omissions.

INTRODUCTION

Index	1
Assembly solutions	2
Material specifications - components	3
Scaling table	4
Scaling request form	5
Instructions for assembling - lubrication	6
Profile specifications	8

PORTALS WITH ONE AXIS

PA 2X max load capacity 200kg	10
PA 3X max load capacity 300kg	12
PA 4X max load capacity 400kg	14
PA 5X max load capacity 500kg	16
PA 6X max load capacity 600kg	18
PA 8X max load capacity 800kg	20
PA 10X max load capacity 1000kg	22

PORTALS WITH TWO AXIS

PA 2/1 max load capacity 100kg	24
PA 3/1 max load capacity 100kg	26
PA 4/1 max load capacity 100kg	28
PA 5/2 max load capacity 200kg	30
PA 6/2 max load capacity 200kg	32
PA 6/4 max load capacity 400kg	34
PA 8/3 max load capacity 300kg	36
PA 8/6 max load capacity 600kg	38
PA 10/6 max load capacity 600kg	40
PA 10/8 max load capacity 800kg	42

ACCESSORIES

Nuts and plates - thread bushings	44
Steel linear guide rails, racks straight and helical teeth.	46
Toothed pinions, micro-switch cams, spare parts.	47

CODE COMPOSITION

Order code setting	48
--------------------	----

EXAMPLES OF APPLICATIONS

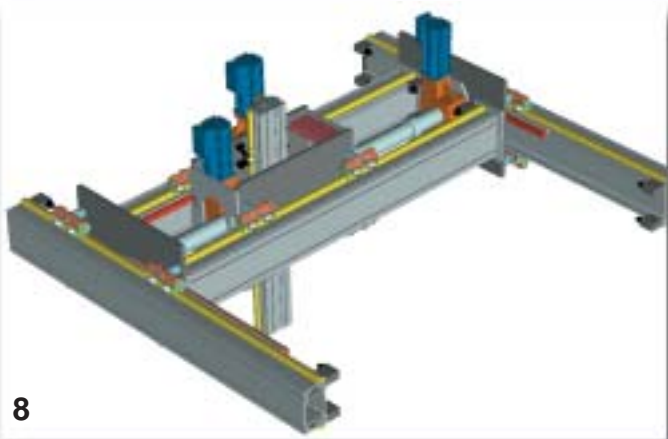
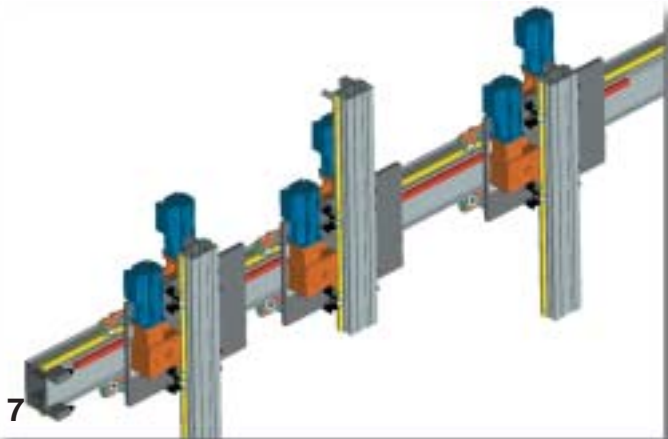
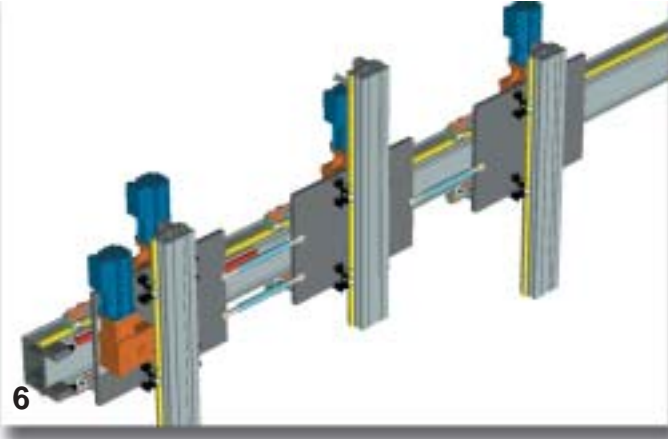
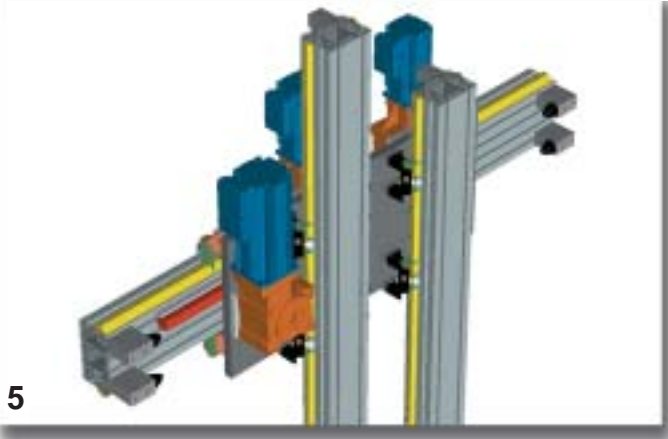
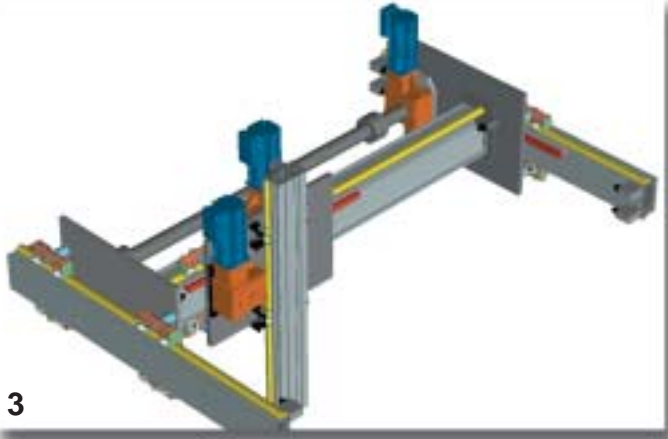
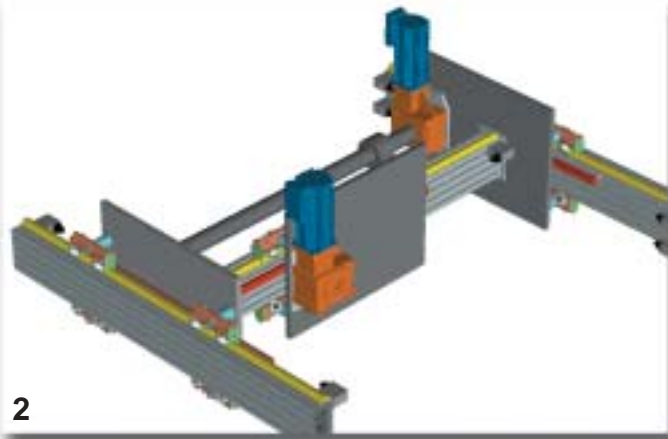
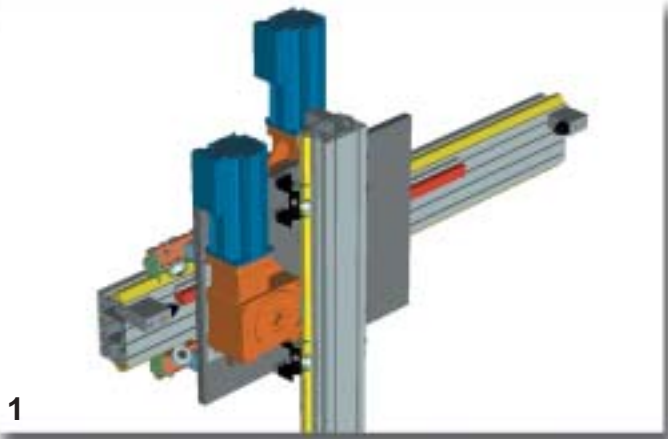

Beams

Obtained from Tecno Center's extruded and anodized section bars, made of hardened and tempered aluminium casting alloy Al Mg Si 0,5, quality F25, Rm N/mm, tolerance according to DIN 1765-3 and DIN 1784-4.

Sections have been expressly designed by Tecno Center to create rigid and light structures suitable for manufacturing linear transfer machines.

(*) Except for Pratyca and Solyda. Valyda and Logyca are anodized only on lengths 9m.

Plates

Obtained from extra fine rolled sections made of high-performance casting alloy. Resistance to tensile stress Rm 290 N/mm, HB 77.

Each plate undergoes anodization just after chip machining. Natural colour.

Linear guide rails

Made of special treated high-carbon steel. We can offer both hardened and tempered guides, width 55 mm (max. Length tempered without joint 8200 mm) or 35 mm (max. Length without joint 6000 mm). Features: hardness of hardened guides HRc 56 min – Rm > 950 N/mm – Ra 2.

Roller slides

Made of hardened casting alloy extrusion Al Mg Si, quality F25, HB 100, resistance to tensile stress Rm 310 N/mm, equipped with scraper to keep the rolling surface clean. Backlash between rollers and adjustable gears, long-life rollers, without internal backlash.

Available both rigid and self-aligning, with different roller diameters: 40mm, 52mm, and 62mm.

Racks

Made of high-resistant steel drawn components, induction hardening tooth by tooth on request, available in three versions: 20x20, 30x30 and 40x40mm. On request we supply pignon and racks grounded and/or helical.

E-chain cable carrier

Usually not included. Yet we supply the supports adjustable in length and width. Our standards design provide for the sizes of the standard chains available on the market.

Components

For components and accessories please see **Tecline components** catalogue

Hardened steel guides

Pins for fixing the roller slides to the plate

Plates for racks fixing

Cams and cam-holders

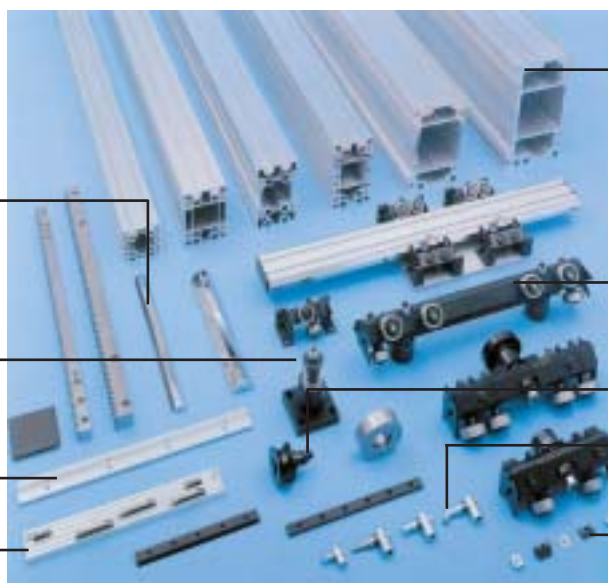

Casting alloy sections

Roller slides

Shaped rollers for light working connecting

PVS (sections system)

Inserts (for the assembly of accessories in the sections slots)

With the product range offered by Tecno Center and the support of its Technical Department, you can have at your disposal a wide range of solutions for any requirement of linear positioning.

Please ask for the catalogues shown in the back-cover.

4 Scaling table

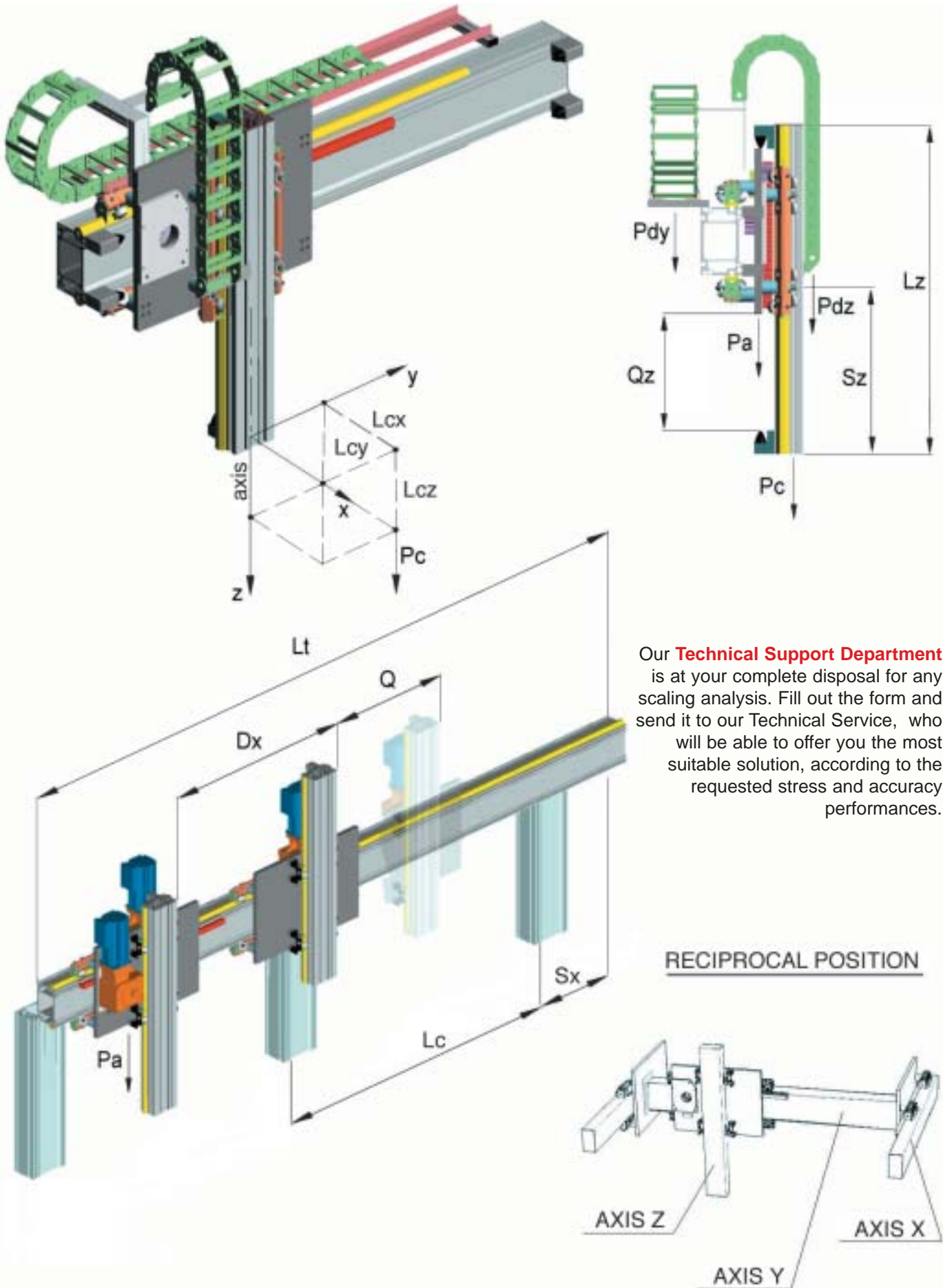

Our **Technical Support Department** is at your complete disposal for any scaling analysis. Fill out the form and send it to our Technical Service, who will be able to offer you the most suitable solution, according to the requested stress and accuracy performances.

RECIPROCAL POSITION

Scaling request form

For a correct definition of the portal, please state the requested technical data by sending this form to our Technical Service.

Date:**Request No:**.....
Filled out by:.....
Company:
Address:.....
Phone:**Fax:**.....
E-mail:.....

Tecno Center C.so Lombardia, 41
 10078 Venaria Reale (TO) ITALY
 Phone: ++39-011 455 11 21 (R.A.)
 Fax.: ++39-011 455 75 95
 e-mail: info@tecno-center.it
 Web: www.tecno-center.it

SCALING TABLE

TECLINE PORTAL SYSTEMS

Required data

ASSEMBLY SOLUTION (see page.2) no.

Beam total length

Load capacity useful with gupper (add Z-axis for Y and X-axes)

Tooling weight on carriage (reduction unit, cylinder, OPTIONAL)

Weight distributed on the beam (chains, cable)

Beam supports

Possible overhang

Max. Bay (the biggest)

LX height

LY height

LZ height

SZ length (max. overhamp of Z-axis from last roller slide)

Possible axis distance between carriages (see solutions 6-7 at page 2)

Transmission performance

Stroke

Speed

Acceleration

Total time

Positioning accuracy and requested repeatability

Work environment (temperature and cleaning)

Daily working cycles

Z Axis	Y Axis	X Axis	
Lz <input type="text"/>	Ly <input type="text"/>	Lx <input type="text"/>	[m]
Pc <input type="text"/>	Pt <input type="text"/>	Pax <input type="text"/>	[Kg]
Pdz <input type="text"/>	Pay <input type="text"/>	Pdx <input type="text"/>	[Kg]
	Pdy <input type="text"/>	Pdx <input type="text"/>	[Kg/m]
	n° <input type="text"/>	Sx <input type="text"/>	[mm]
	Sy <input type="text"/>	Sx <input type="text"/>	[mm]
	Lc <input type="text"/>	Sx <input type="text"/>	[mm]
Lx <input type="text"/>			[mm]
Ly <input type="text"/>			[mm]
Lz <input type="text"/>			[mm]
Sz <input type="text"/>			[mm]
	Dy <input type="text"/>	Dx <input type="text"/>	[mm]
f= <input type="text"/>			
Qz <input type="text"/>	Qy <input type="text"/>	Qx <input type="text"/>	[m]
V <input type="text"/>			[m/m1']
A <input type="text"/>			[m/sec ²]
T <input type="text"/>			[sec]
+/- <input type="text"/>			
No. <input type="text"/>			



Working cycle

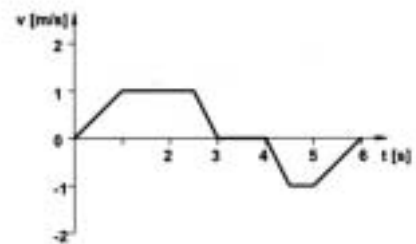

Example of working cycle.

Instructions for correct assembly

A - Translation system. Features.

The translation system consists of a plate equipped with four roller slides: two have concentric pins and two have eccentric pins. The eccentric pins help adjusting the backlash between the roller slides and the sliding track. It is important to check if the position of the rollers on the sliding guides can support the max. workload.

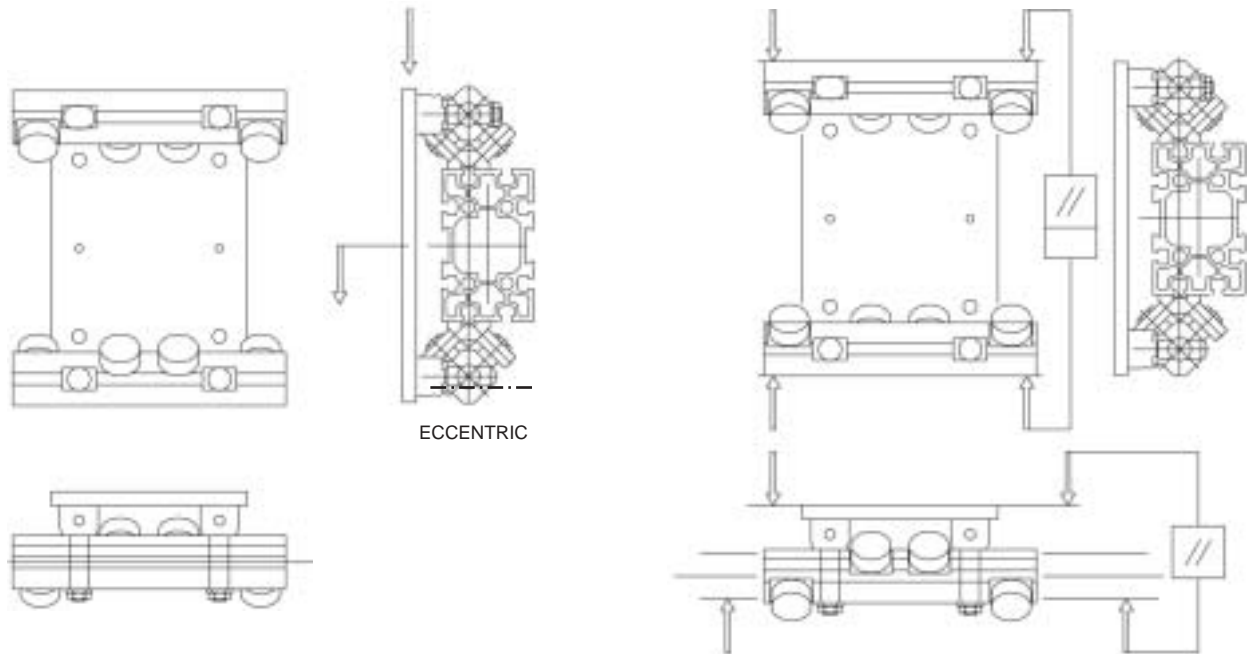

B - Alignment

All sliding points must be perfectly aligned.

C - Racks assembling

In case of translation with rack, the parallelism between the teeth axis and the sliding system must be perfect.

D - Assembling operations and adjustment of the roller slide

It is important to check the position of the roller slide as indicated at point A. Once the alignment has been checked, drive the roller slides with concentric pins to the sliding tracks, then perform taking up by adjusting the eccentric pins until there is absence of backlash and the carriage can easily slide on the bar.

Warning: preloading can be easily achieved and may produce early wearing.

Note: always keep the sliding high. Otherwise repeat the adjustment operations.

E - Locking operations

Make sure all components are locked with screws in accordance with the tightening torques prescribed.

Rollers and roller slides

Both the roller slides and the V-rollers are fitted with a “for life” lubricating system and there is no need of maintenance during the normal mean-life of manipulation tools, if the system is used correctly.

Please avoid the use of solvents to clean the rollers, since it might clean up the grease cover necessary for the lubrication of the sliding elements.

It is possible to lubricate by carefully dropping lithium soap grease according to DIN 51825 – K3N.

Pinion and rack

These parts must be regularly lubricated with a gear grease. (for high working pressures)

Linear guide rails

If the rails are correctly assembled, they do not need any lubrication, which could make them dirty.

In case the surface of the rails and / or of the rolling parts shows any defect (e.g. pitting), this may be due to a misalignment of the parts or to an excessive load.

In this case replace all worn parts and check geometry and alignments.

Accuracy

The accuracy of this system is based on the tolerance of:

1. linear guide rails
2. rolling parts
3. motor system (e.g. pinion and rack)

Linear guide rails

Made of special treated high-carriagebon steel.

They have a size accuracy as shown in the picture below and can be supplied tempered or induction-hardened along the sliding sides.

Hardness: hardened min. 55HRC

Tempered: 260 HB

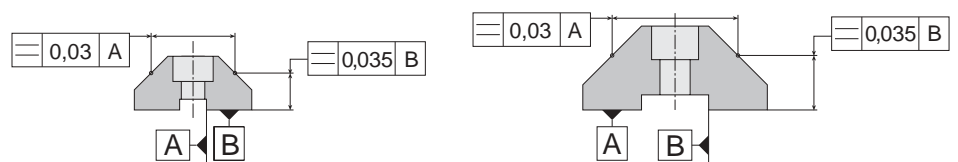

Rolling parts

100 cr6 steel rollers, with hardness min. 60HRC and equipped with double-surface sealing ring. They usually consist of two ball scrolls with bias bearing allowing a low friction coefficient. (Approx. 0,03mm)

Roller tolerance corresponds to DIN 620, whilst the load and calculation coefficients correspond to DIN ISO 281 and to DIN ISO 76.

Roller slides

They consist of a body made of hardened casting alloy extrusion with high resistance to tensile stress. Rollers are assembled with alloyed steel pins. (R=80 Kg/mm)

Roller slides can be fixed on eccentric pins to obtain a better control of the coupling with the linear guide rail.

Special connection plates for roller slides are available on request.

Motor system

Usually at customer's change. On request we assembly the reduction unit supplied by the customer.

Profile Specifications

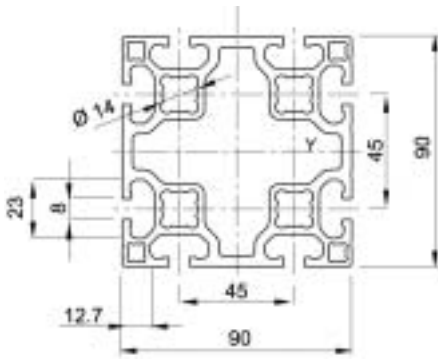

E 01-4 (90x90)

Weight	approx. 6 [kg/m]
Max. Length	6 [m]
Moment of inertia IY	2.027.000 [mm ⁴]
Moment of inertia IX	2.027.000 [mm ⁴]
Torque	1.100.000 [mm ⁴]

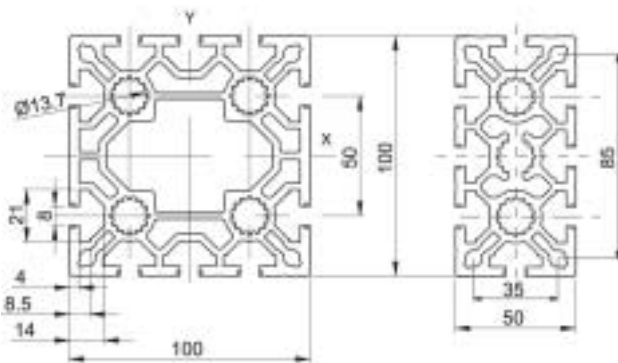

PROFILES MA 1-5 (100x100) MA 1-2 (100x50)

Weight	approx. 9 [kg/m]	approx.. 6,2 [kg/m]
Max. Length	6 [m]	6 [m]
Moment of inertia IY	3.650.000 [mm ⁴]	528.000 [mm ⁴]
Moment of inertia IX	3.800.000 [mm ⁴]	1.986.600 [mm ⁴]
Torque	1.900.000 [mm ⁴]	

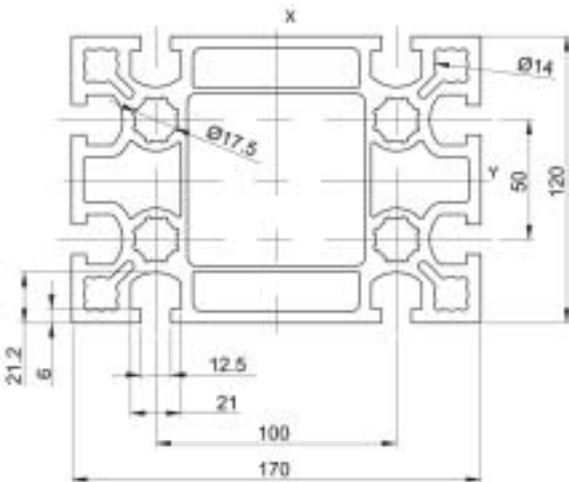

STATYCA (170x120) Code 202.1753

Weight	approx. 17 [kg/m]
Max. Length	6 [m]
Moment of inertia IY	10.200.000 [mm ⁴]
Moment of inertia IX	20.360.000 [mm ⁴]
Torque	8.460.000 [mm ⁴]

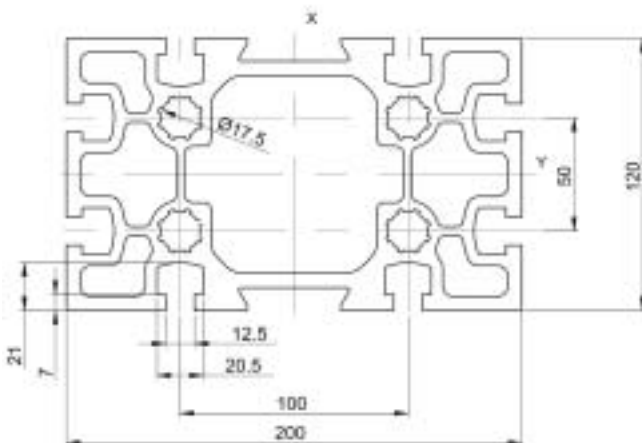

VALYDA (200x120) Cod. 202.1146

Weight	approx. 21 [kg/m]
Max. Length	12 [m]
Moment of inertia IY	12.900.000 [mm ⁴]
Moment of inertia IX	32.900.000 [mm ⁴]
Torque	9.430.000

Anodized up to 9[m] only

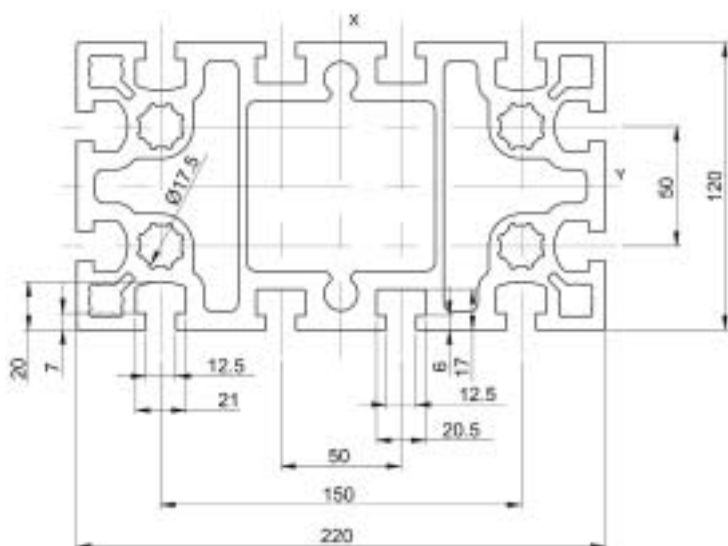
LOGYCA (220x120) Code 202.2184

Weight	approx. 25 [kg/m]
Max. length	12 [m]
Moment of inertia IY	15.650.000 [mm ⁴]
Moment of inertia IX	46.550.000 [mm ⁴]
Torque	13.100.000 [mm ⁴]
Anodized up to 9 [m] only	

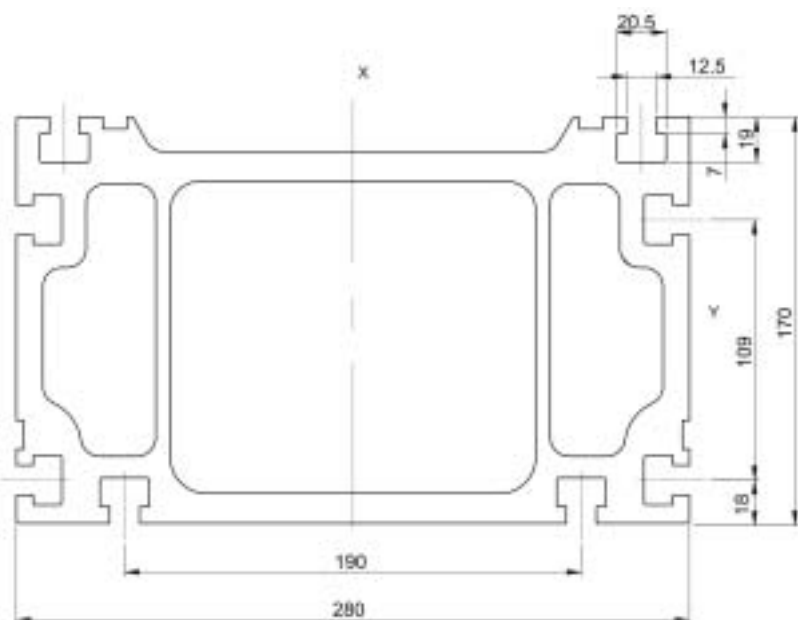
PRATYCA (280x170) Code 202.1147

Weight	approx. 40 [kg/m]
Max. length	12 [m]
Moment of inertia IY	50.250.000 [mm ⁴]
Moment of inertia IX	134.000.000 [mm ⁴]
Torque	72.700.000 [mm ⁴]
Usually not anodized.	

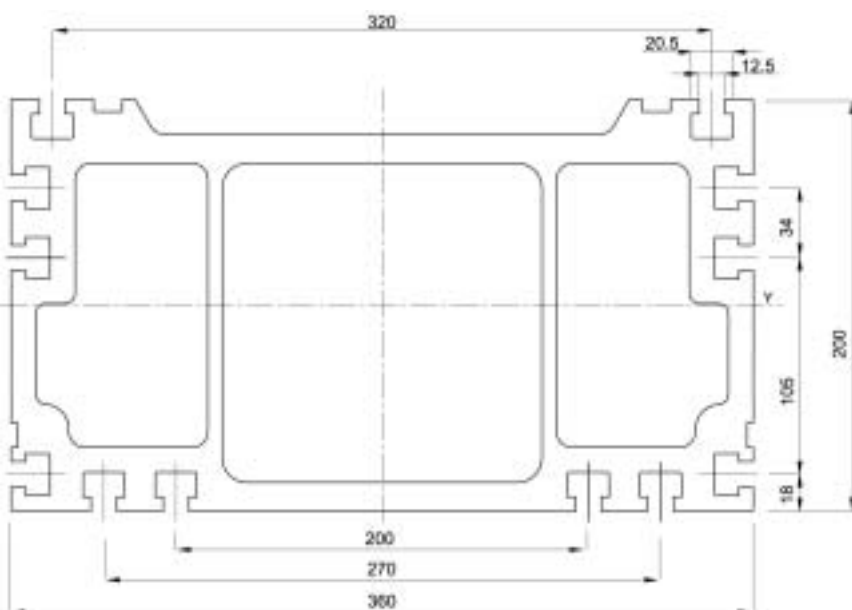
SOLYDA (360x200) Code 202.0342

Weight	approx. 60 [kg/m]
Max. length	12 [m]
Moment of inertia IY	103.280.000 [mm ⁴]
Moment of inertia IX	317.540.000 [mm ⁴]
Torque	145.000.000 [mm ⁴]
Usually not anodized.	

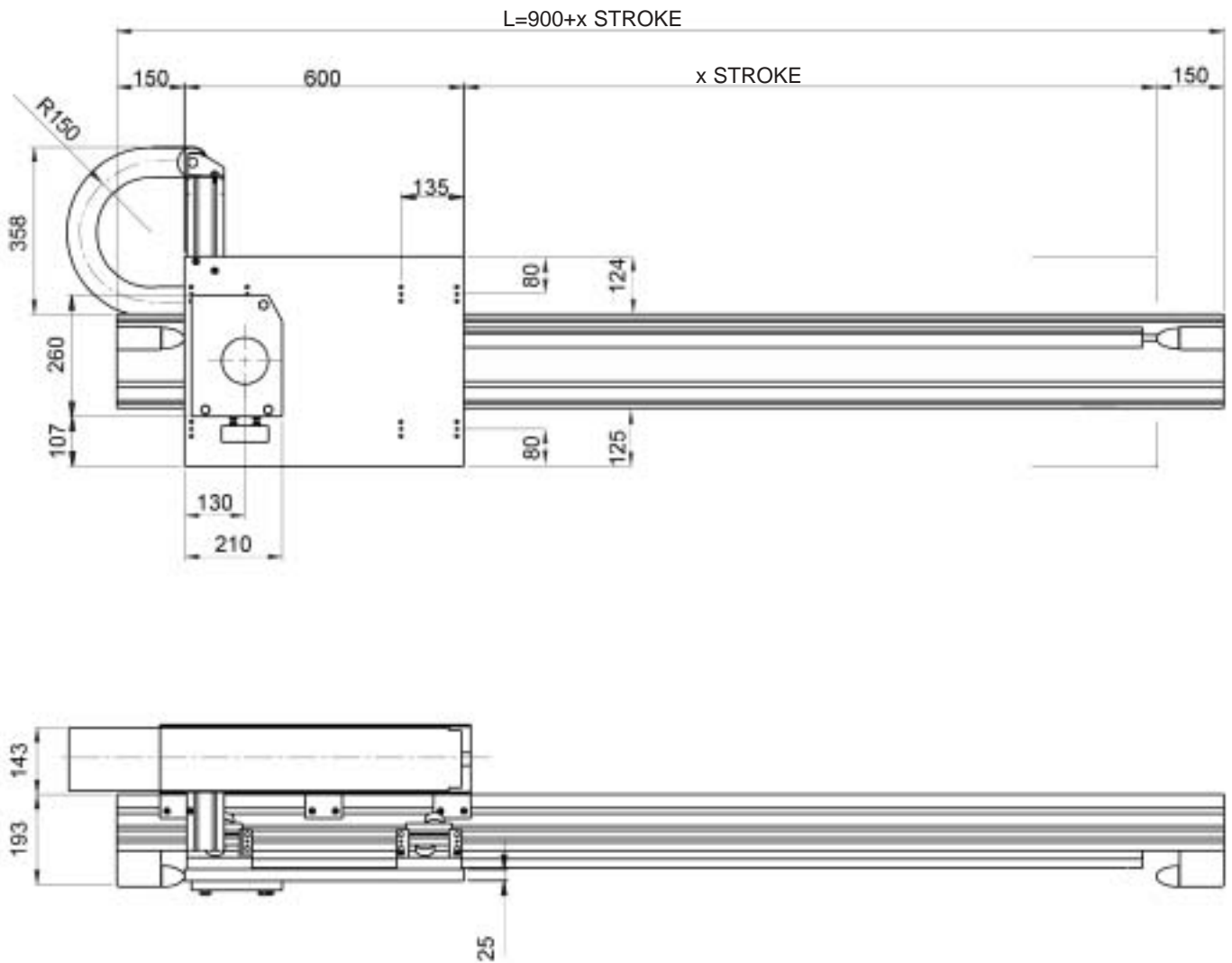

All reported data refer to indicative values to determine the appropriate portal

Performances:	X Axis
Max. load	200[Kg]
Max. translation speed	5 [m/s]
Repositioning accuracy	$\pm 0,5$ [mm]
Max. stroke	29 [m]
Max. bay	6 [m]

Each mentioned value must be considered as the max. performance of the item it refers to.
For a correct scaling please fill out the form at page 5 and send it to our Technical Service.

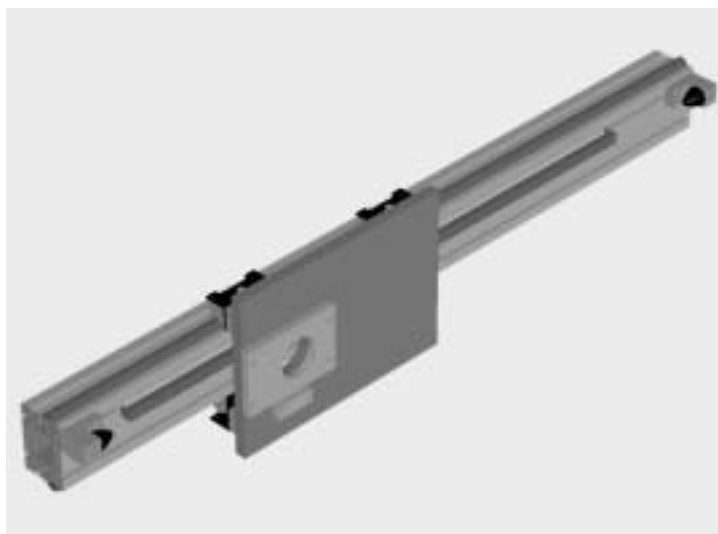
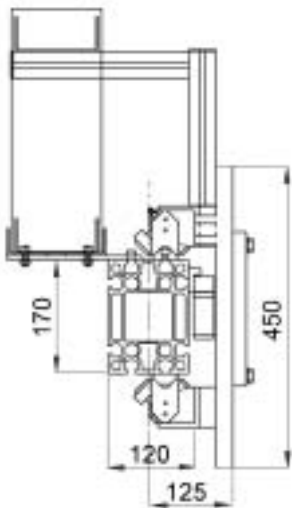

Cutaway view of the longitudinal slot of the section bar

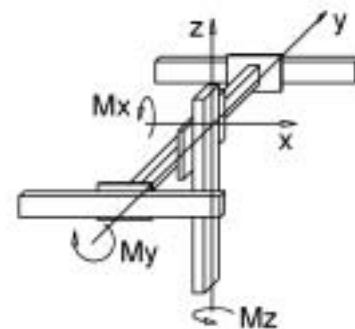
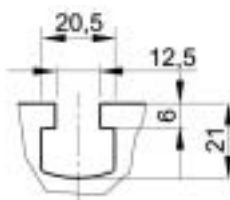

Construction data	X Axis
Beam	Statyca (see page 8/9)*
Rack	30x30 [mm] - module 3
Linear guide rail	35x16 (hardened and polished*)
Translation	4 roller slides (each: 2 Ø40* rollers)
E-chain inside dimensions	115x45 [mm]
Pinion diameter	63 [mm]

Weights	X Axis
"Base" portal ($x_{stroke}=0$)	$M_{base} = 63$ [Kg] approx.
Carriage (plate+roller slides)	$M_{slide} = 32$ [Kg] approx.
1000mm beam (incl.linear guide rails and rack)	$q_x = 32$ [Kg] approx.

To calculate the portal total weight please use the following formula: $M_{tot} = M_{base} + [q_x \cdot x_{stroke}] / 1000$

Where x_{stroke} is expressed in mm.

(*) For any further information please see the Tecline Components catalogue.

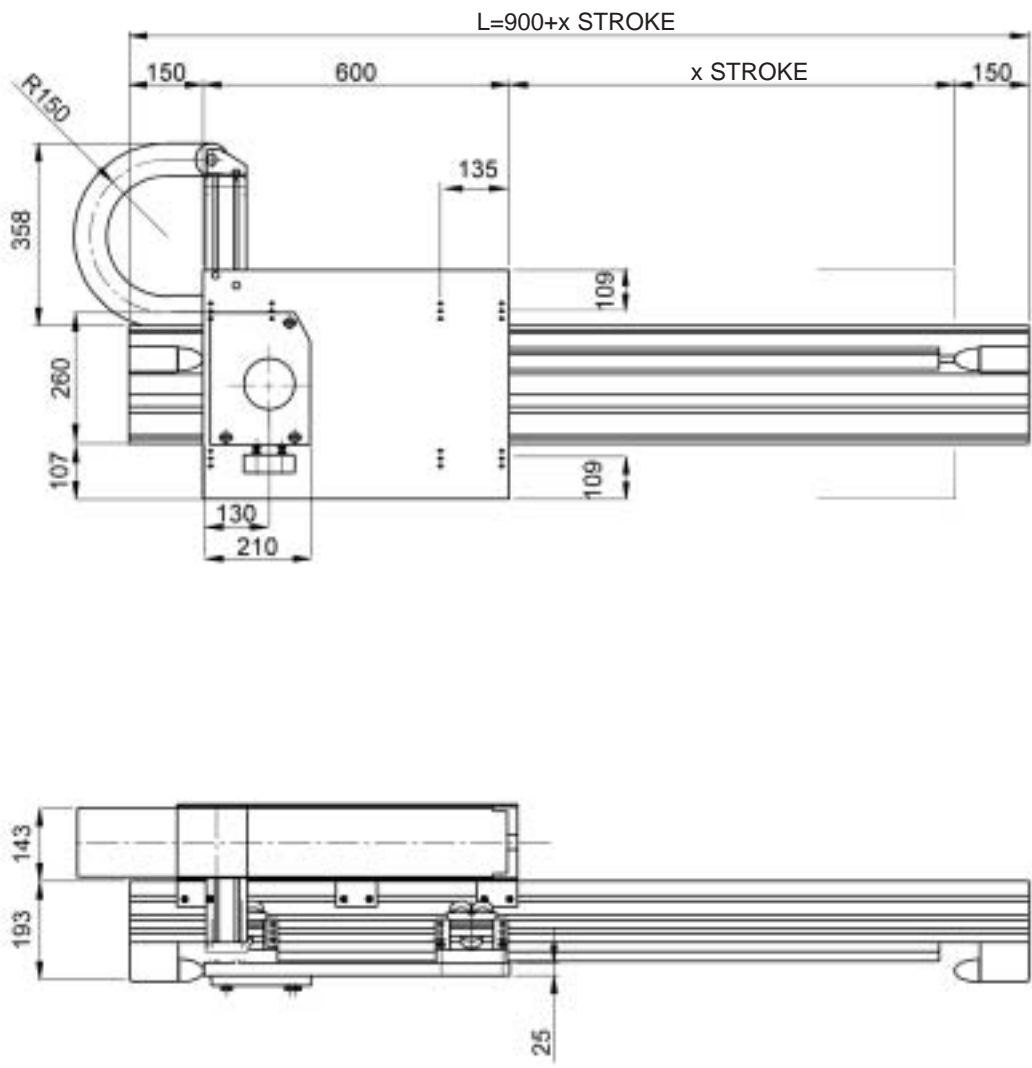

All reported data refer to indicative values to determine the appropriate portal

Performances	X Axis
Max. load	300[Kg]
Max. translation speed	5 [m/s]
Repositioning accuracy	$\pm 0,5$ [mm]
Max. stroke	47 [m]
Max. bay	12 [m]

Each mentioned value must be considered as the max. performance of the item it refers to.
For a correct scaling please fill out the form at page 5 and send it to our Technical Service.

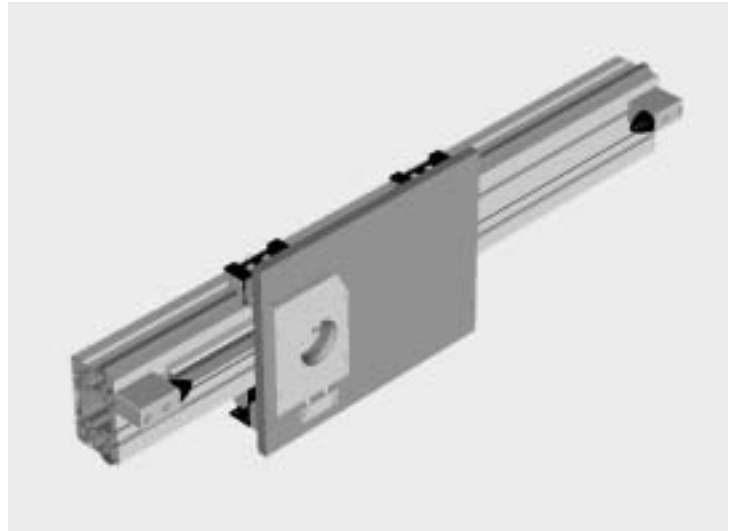
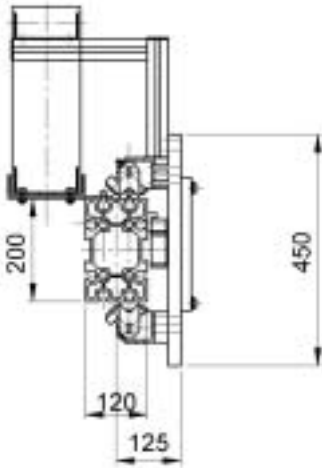

Cutaway view of the longitudinal slot of the section bar

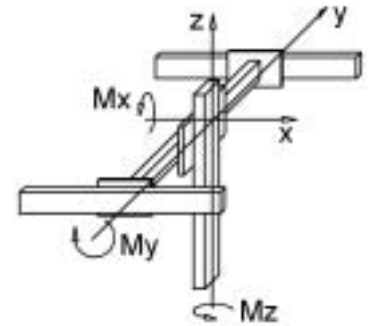
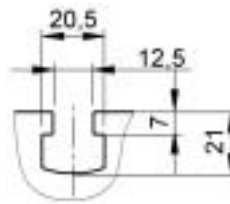

Construction data	X Axis
Beam	Valyda (see page 8/9)*
Rack	30x30 [mm] - module 3
Linear guide rail	35x16 (hardened and polished*)
Translation	4 roller slides (each: 3 Ø40* rollers)
E-chain inside dimensions	115x45 [mm]
Pinion diameter	63 [mm]

Weights	X Axis
"Base" portal ($x_{stroke}=0$)	$M_{base} = 67$ [Kg] approx.
Carriage (plate+roller slides)	$M_{slide} = 32$ [Kg] approx.
1000mm beam (incl.linear guide rails and rack)	$q_x = 37$ [Kg] approx.

To calculate the portal total weight please use the following formula: $M_{tot} = M_{base} + [q_x \cdot x_{stroke}] / 1000$

Where x_{stroke} is expressed in mm.

(*) For any further information please see the Tecline Components catalogue.

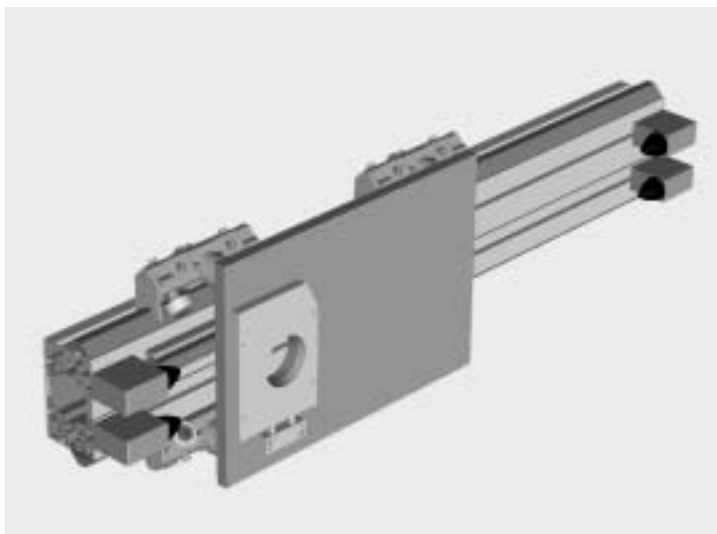
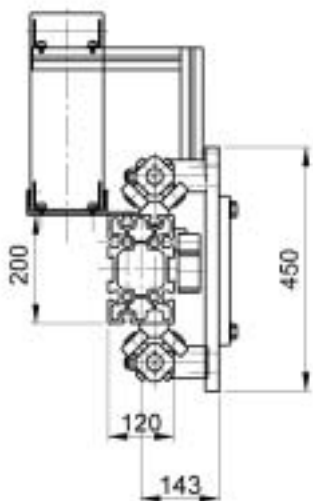

Cutaway view of the longitudinal slot of the section bar

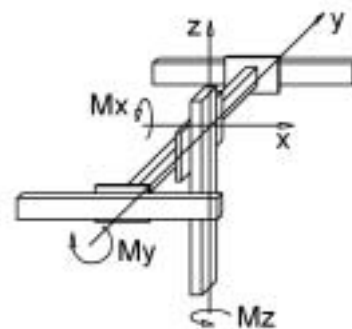
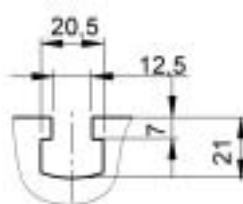

Construction data	X Axis
Beam	Valyda (see page 8/9)*
Rack	40x40 [mm] - module 4
Linear guide rail	35x16 (hardened and polished*)
Translation	4 roller slides (each: 4 Ø52* rollers)
E-chain inside dimensions	115x45 [mm]
Pinion diameter	68 [mm]

Weights	X Axis
"Base" portal ($x_{stroke}=0$)	$M_{base} = 97$ [Kg] approx.
Carriage (plate+roller slides)	$M_{slide} = 51$ [Kg] approx.
1000mm beam (incl.linear guide rails and rack)	$q_x = 49$ [Kg] approx.

To calculate the portal total weight please use the following formula: $M_{tot} = M_{base} + [q_x \cdot x_{stroke}] / 1000$

Where x_{stroke} is expressed in mm.

(*) For any further information please see the Tecline Components catalogue.

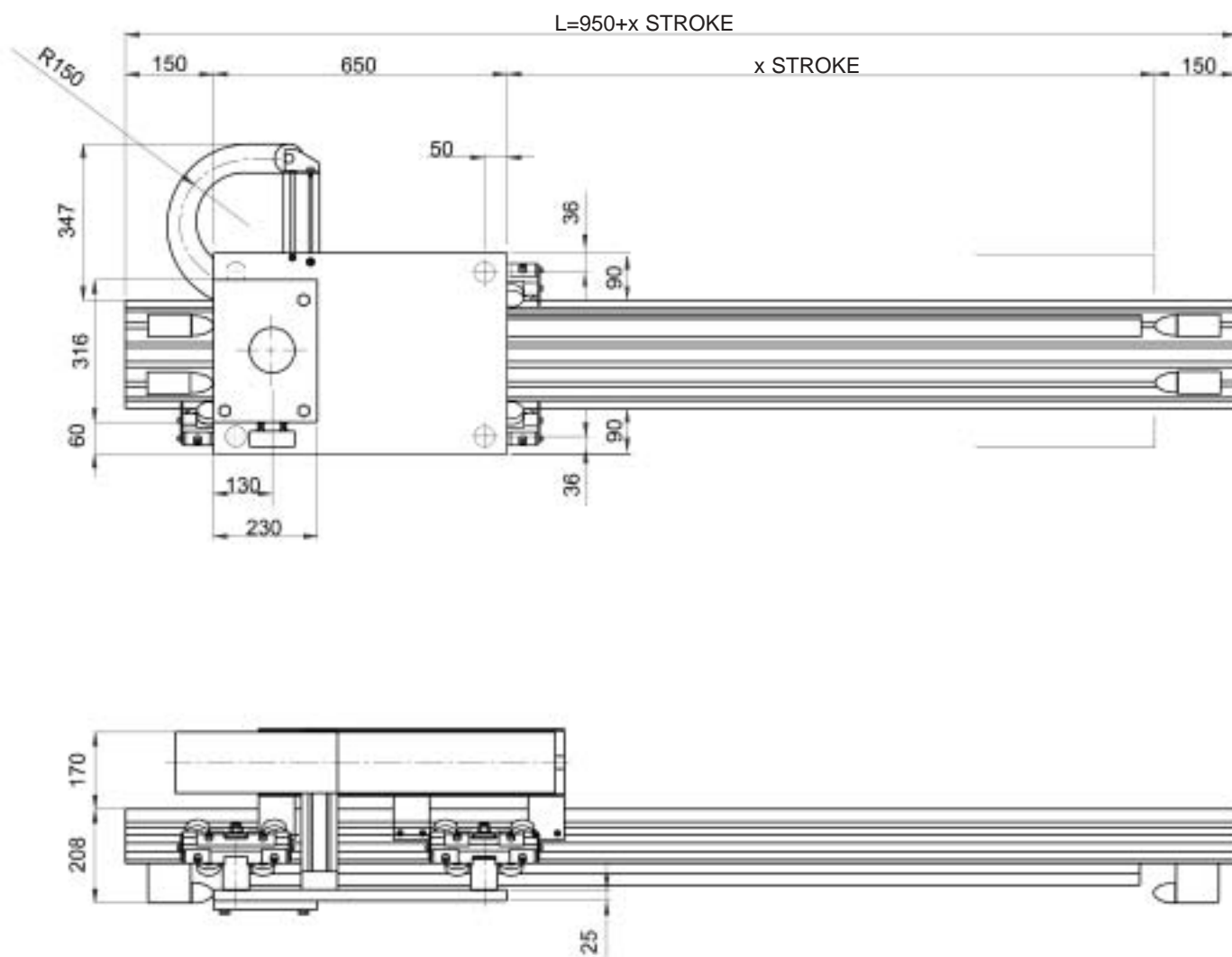

All reported data refer to indicative values to determine the appropriate portal

Performances	Y Axis
Max. load	500 [Kg]
Max. translation speed	5 [m/s]
Repositioning accuracy	$\pm 0,5$ [mm]
Max. stroke	47 [m]
Max. bay	12 [m]

Each mentioned value must be considered as the max. performance of the item it refers to.

For a correct scaling please fill out the form at page 5 and send it to our Technical Service.

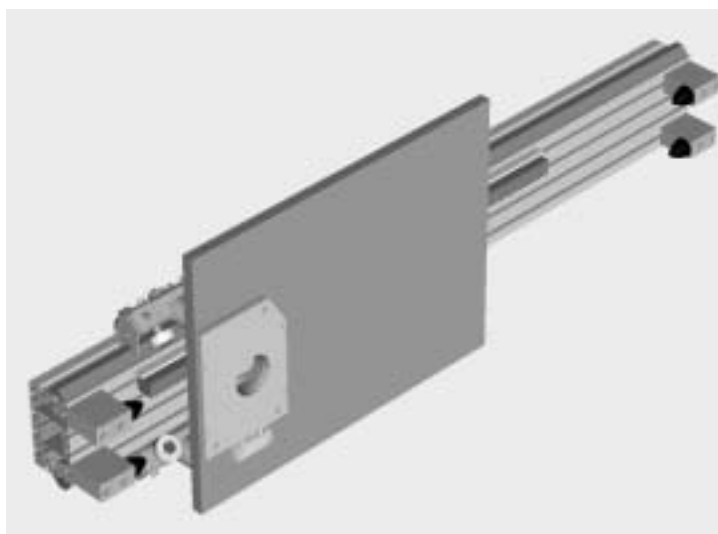
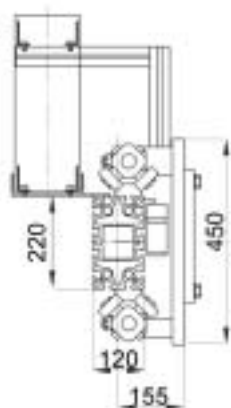

Cutaway view of the longitudinal slot of the section bar

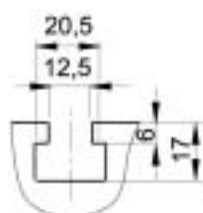

Central slots

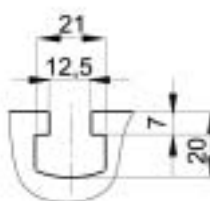

Peripheral slots

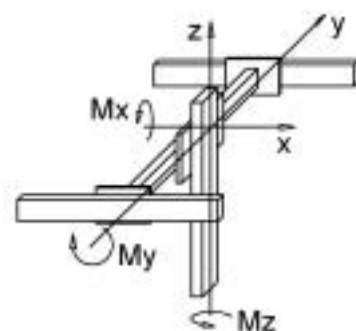

Construction data	X Axis
Beam	Logyca (see page 8/9)*
Rack	40x40 [mm] - module 4
Linear guide rail	55x25 (hardened and polished*)
Translation	4 roller slides (each: 4 Ø62* rollers)
E-chain inside dimensions	115x45 [mm]
Pinion diameter	68 [mm]

Weights	X Axis
"Base" portal ($x_{stroke}=0$)	$M_{base} = 105$ [Kg] approx.
Carriage (plate+roller slides)	$M_{slide} = 52$ [Kg] approx.
1000mm beam (incl.linear guide rails and rack)	$q_x = 53$ [Kg] approx.

To calculate the portal total weight please use the following formula: $M_{tot} = M_{base} + [q_x \cdot x_{stroke}] / 1000$

Where x_{stroke} is expressed in mm.

(*) For any further information please see the Tecline Components catalogue.

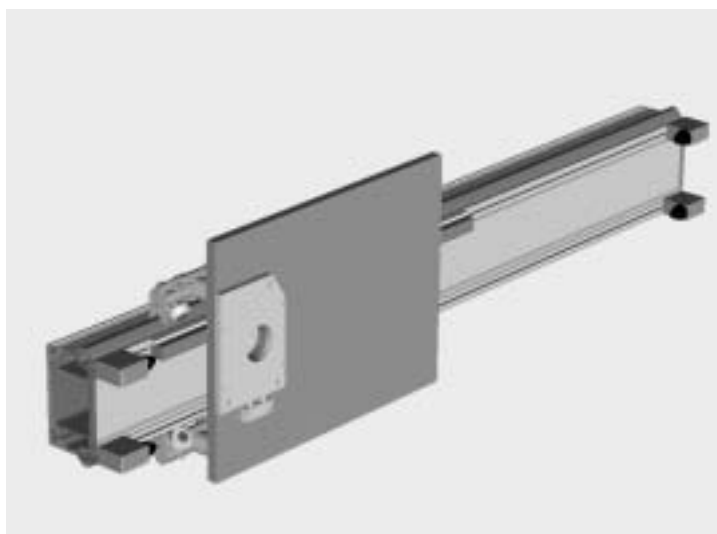
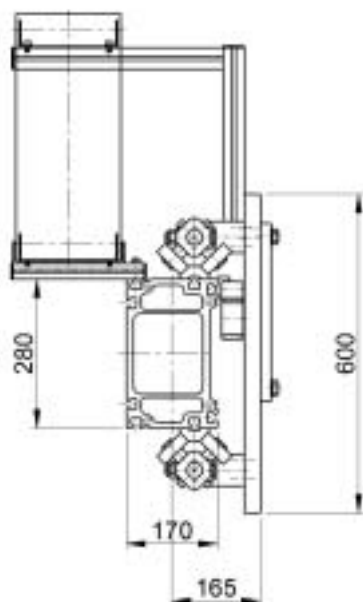

Cutaway view of the longitudinal slot of the section bar

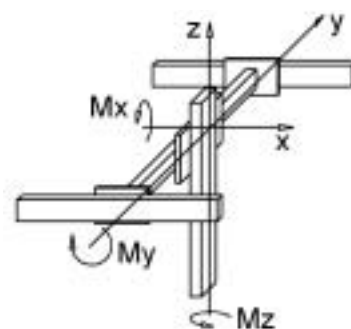
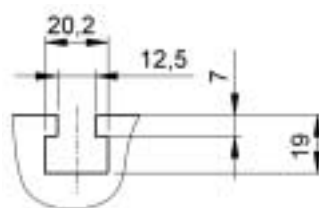

Construction data	X Axis
Beam	Pratyca (see page 8/9)*
Rack	40x40 [mm] - module 4
Linear guide rail	55x25 (hardened and polished*)
Translation	4 roller slides (each: 4 Ø62* rollers)
E-chain inside dimensions	175x45 [mm]
Pinion diameter	68 [mm]

Weights	X Axis
"Base" portal ($x_{stroke}=0$)	$M_{base} = 170$ [Kg] approx.
Carriage (plate+roller slides)	$M_{slide} = 84$ [Kg] approx.
1000mm beam (incl.linear guide rails and rack)	$q_x = 67$ [Kg] approx.

To calculate the portal total weight please use the following formula: $M_{tot} = M_{base} + [q_x \cdot x_{stroke}] / 1000$

Where x_{stroke} is expressed in mm.

(*) For any further information please see the Tecline Components catalogue.

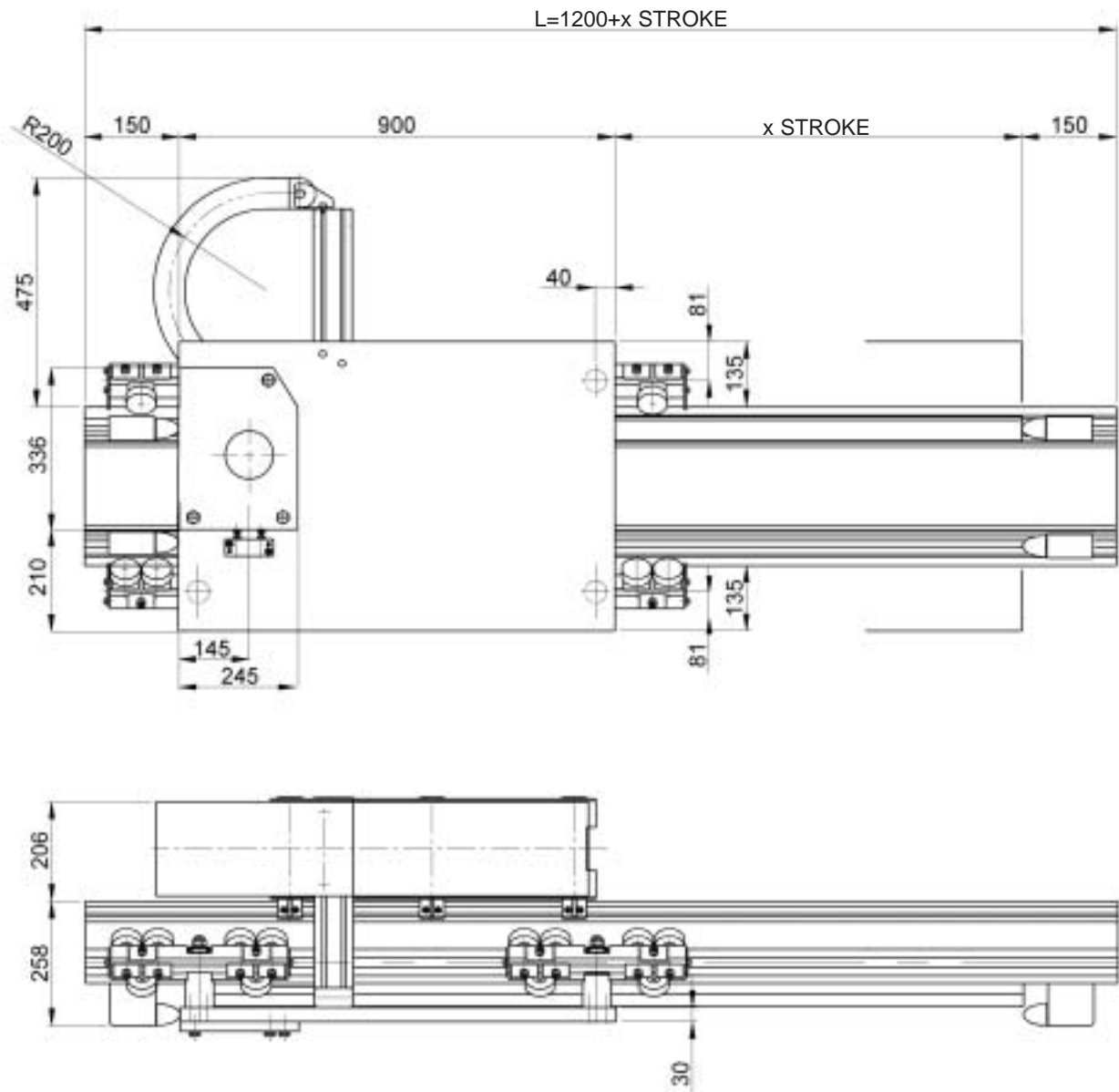

All reported data refer to indicative values to determine the appropriate portal

Performances	Y Axis
Max. load	800[Kg]
Max. translation speed	5 [m/s]
Repositioning accuracy	$\pm 0,5$ [mm]
Max. stroke	46,8 [m]
Max. bay	12 [m]

Each mentioned value must be considered as the max. performance of the item it refers to.

For a correct scaling please fill out the form at page 5 and send it to our Technical Service.

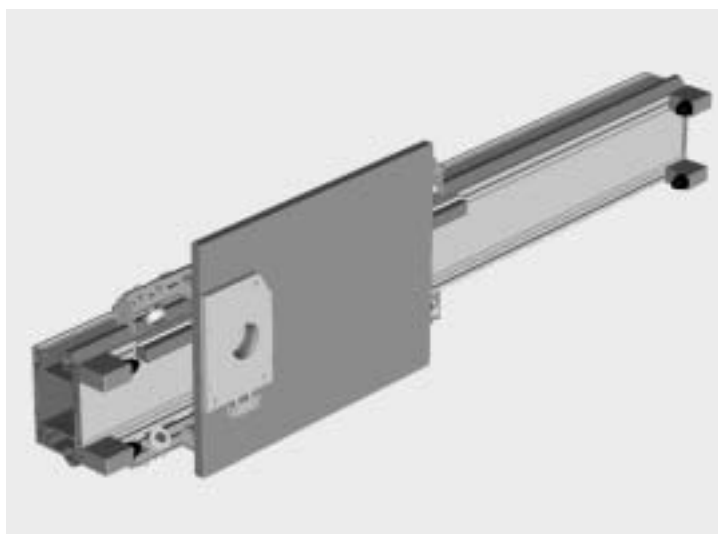
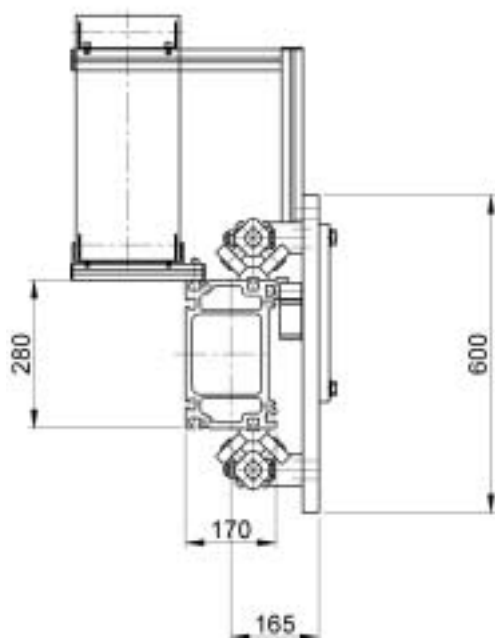

Cutaway view of the longitudinal slot of the section bar

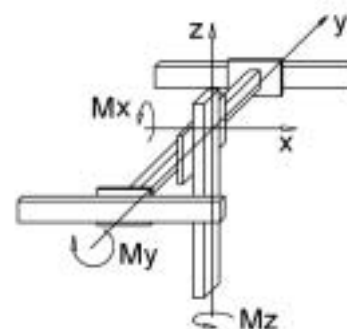
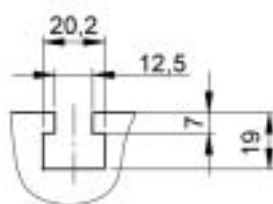

Construction data	X Axis
Beam	Pratyca (see page 8/9)*
Rack	40x40 [mm] - module 4
Linear guide rail	55x25 (hardened and polished*)
Translation	4 roller slides (each: 6 Ø62* rollers)
E-chain inside dimensions	175x45 [mm]
Pinion diameter	68 [mm]

Weights	X Axis
"Base" portal ($x_{stroke}=0$)	$M_{base} = 179$ [Kg] approx.
Carriage (plate+roller slides)	$M_{slide} = 93$ [Kg] approx.
1000mm beam (incl.linear guide rails and rack)	$q_x = 67$ [Kg] approx.

To calculate the portal total weight please use the following formula: $M_{tot} = M_{base} + [q_x \cdot x_{stroke}] / 1000$

Where x_{stroke} is expressed in mm.

(*) For any further information please see the Tecline Components catalogue.

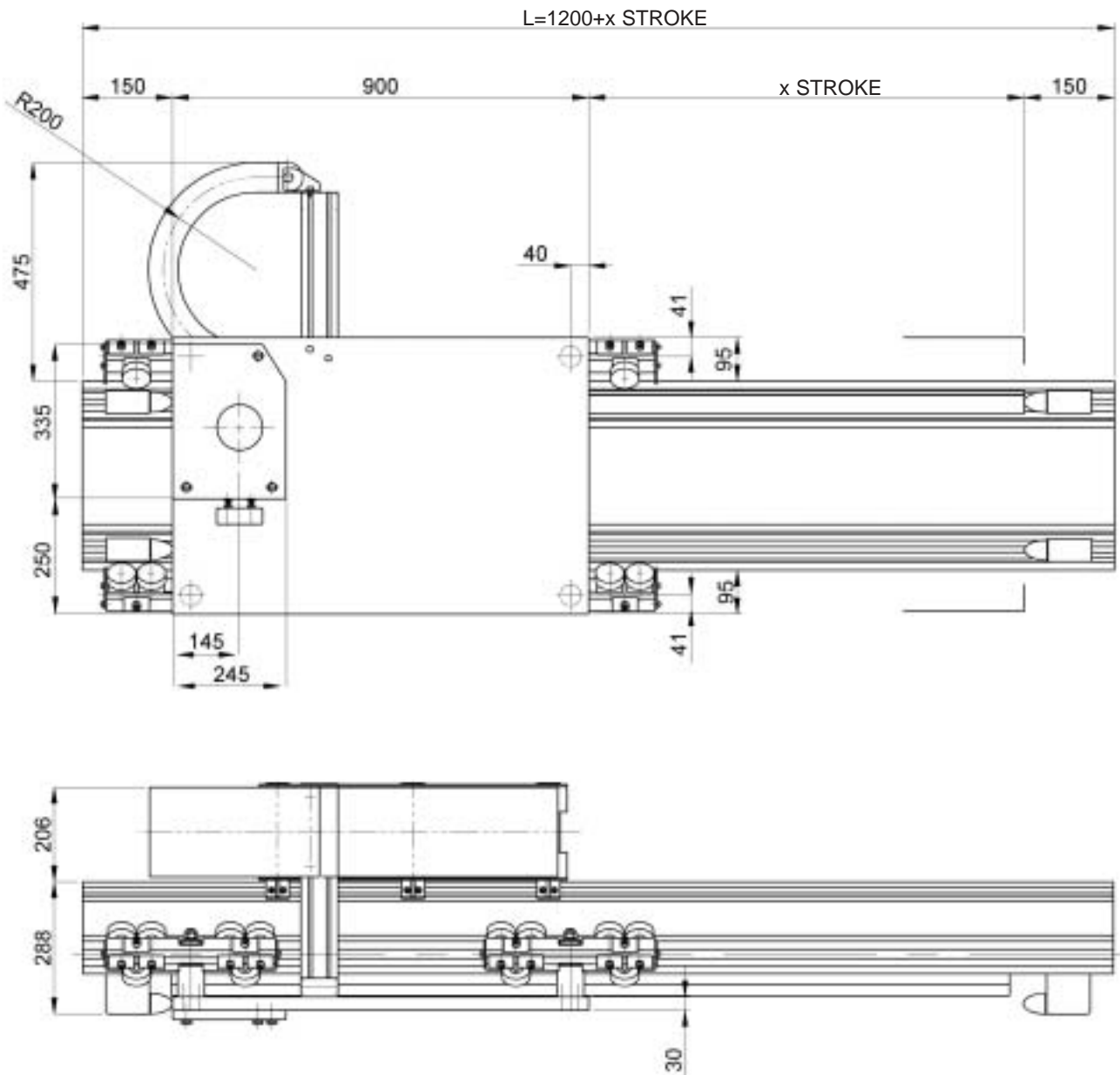

All reported data refer to indicative values to determine the appropriate portal

Performances	X Axis
Max. load	1000[Kg]
Max. translation speed	5 [m/s]
Repositioning accuracy	$\pm 0,5$ [mm]
Max. stroke	46,8 [m]
Max. bay	12 [m]

Each mentioned value must be considered as the max. performance of the item it refers to.

For a correct scaling please fill out the form at page 5 and send it to our Technical Service.

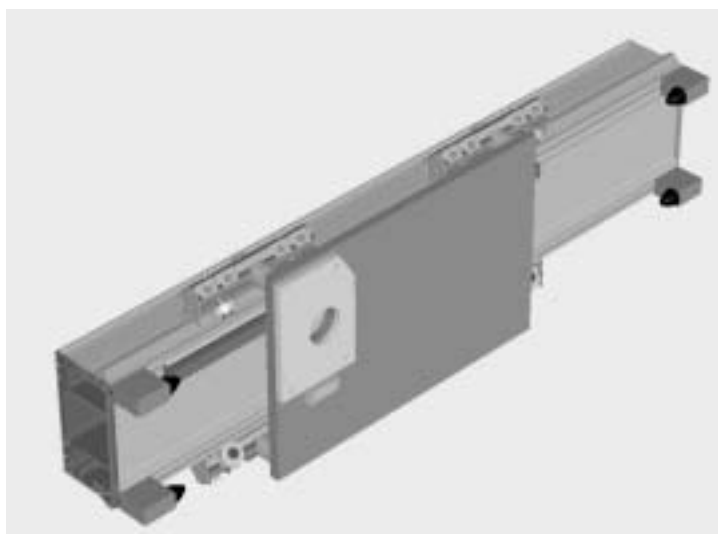
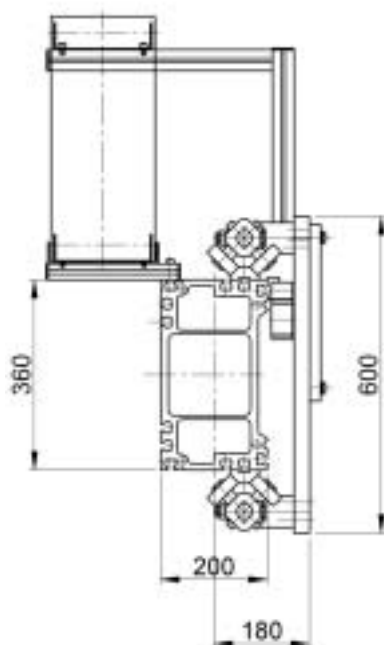

Cutaway view of the longitudinal slot of the section bar

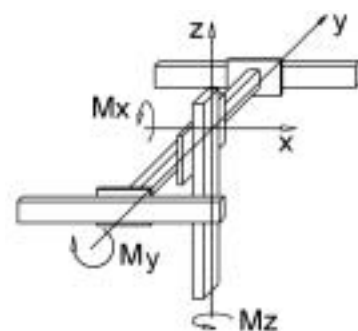
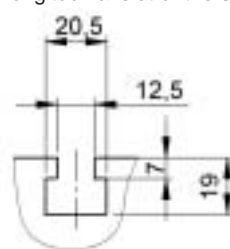

Construction data	X Axis
Beam	Solyda (see page 8/9)*
Rack	40x40 [mm] - module 4
Linear guide rail	55x25 (hardened and polished*)
Translation	4 roller slides (each: 6 Ø62* rollers)
E-chain inside dimensions	175x45 [mm]
Pinion diameter	68 [mm]

Weights	X Axis
"Base" portal ($x_{stroke}=0$)	$M_{base} = 202$ [Kg] approx.
Carriage (plate+roller slides)	$M_{slide} = 93$ [Kg] approx.
1000mm beam (incl.linear guide rails and rack)	$q_x = 86$ [Kg] approx.

To calculate the portal total weight please use the following formula: $M_{tot} = M_{base} + [q_x \cdot x_{stroke}] / 1000$

Where x_{stroke} is expressed in mm.

(*) For any further information please see the Tecline Components catalogue.

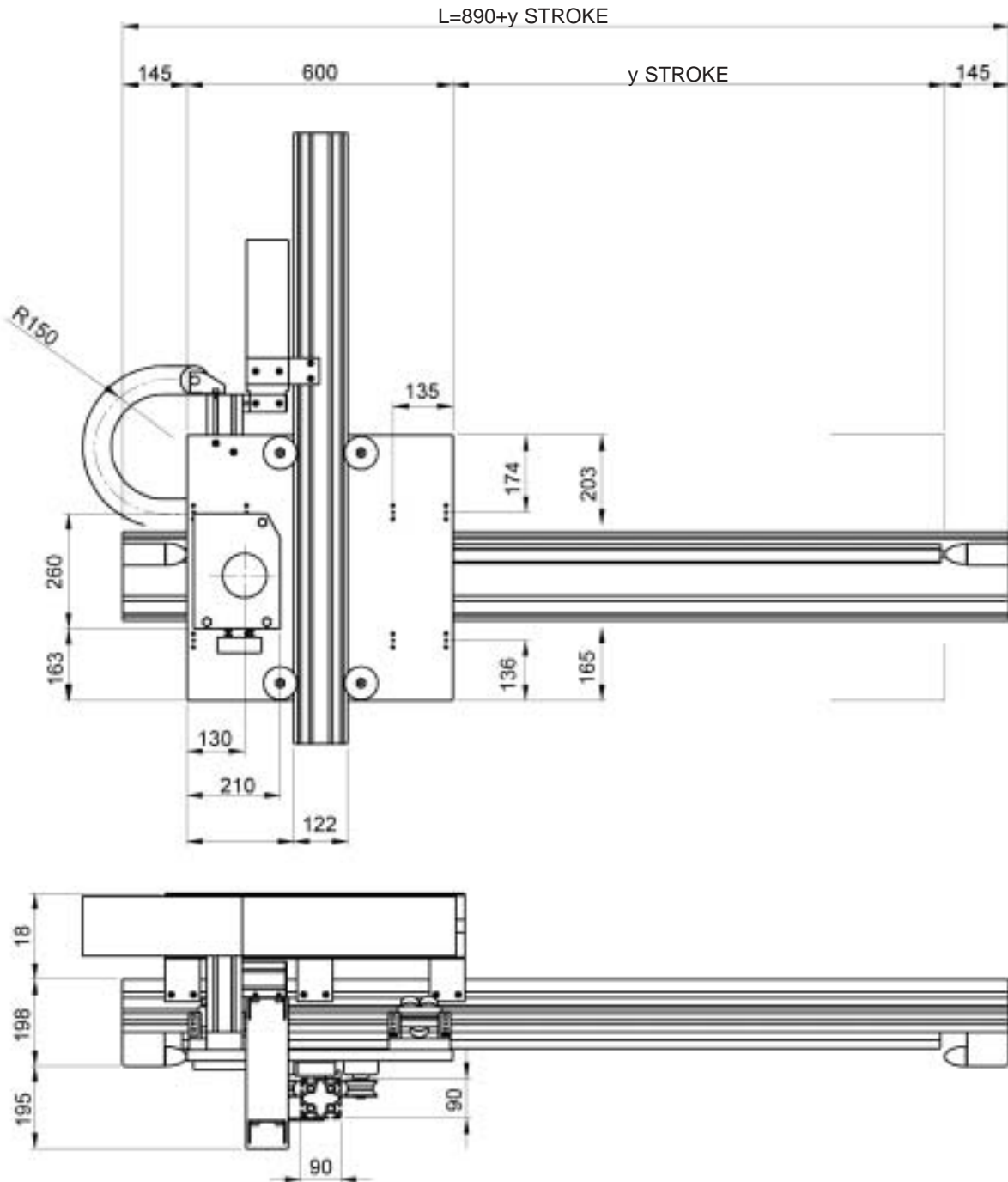

All reported data refer to indicative values to determine the appropriate portal

Performances	X Axis	Z Axis
Max. load	130 [Kg]	70 [Kg]
Max. translation speed	5 [m/s]	2 [m/s]
Repositioning accuracy	±0,5 [mm]	±0,5 [mm]
Max. stroke	29 [m]	2 [m]
Max. bay	6 [m]	-

Each mentioned value must be considered as the max. performance of the item it refers to.

For a correct scaling please fill out the form at page 5 and send it to our Technical Service.

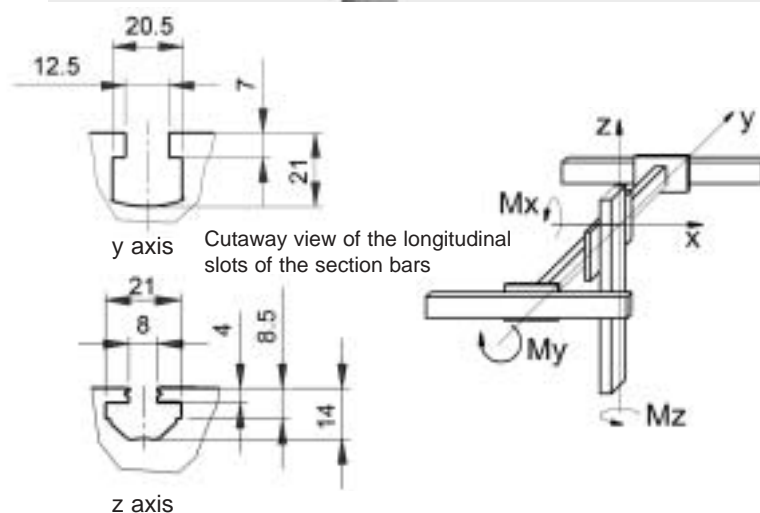
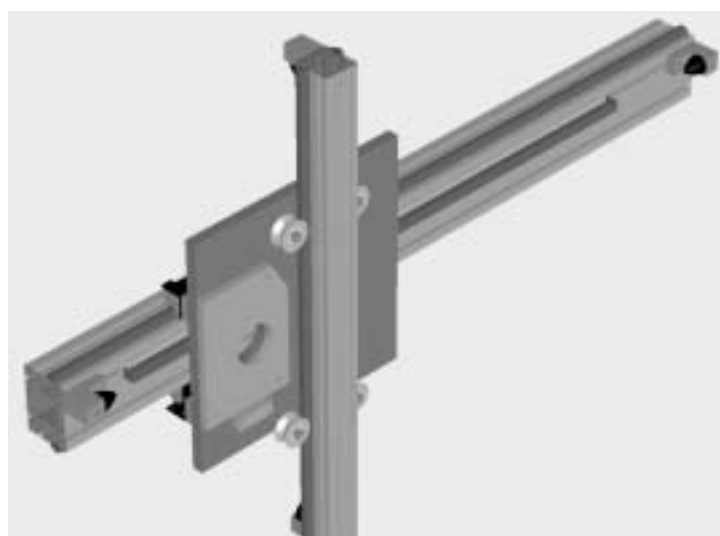
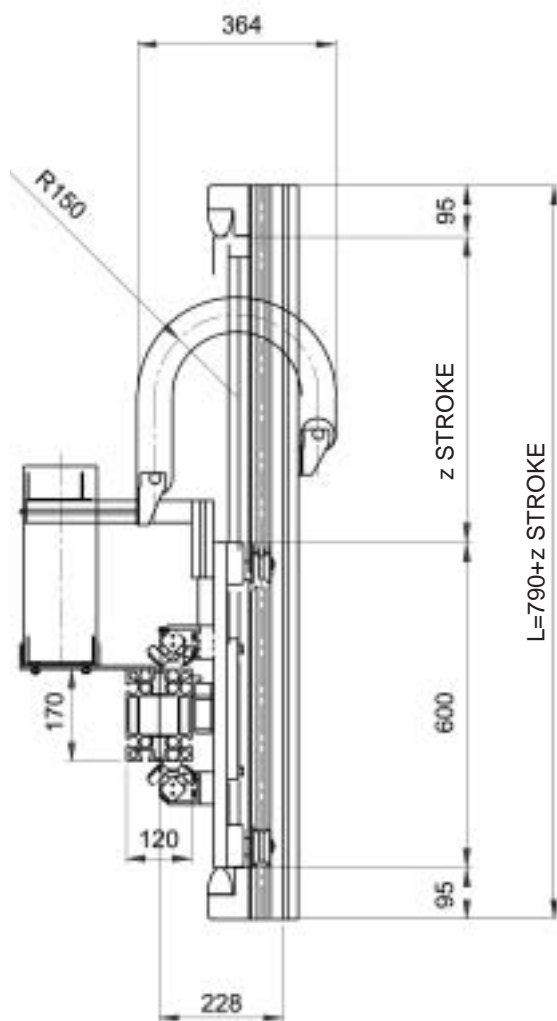

Construction data	Y Axis	Z Axis
Beam	Statyca (see page 8/9)*	E 01-4 (see page 8/9)*
Rack	30x30 [mm] - module 3	20x20 [mm] - module 2
Linear guide rail	35x16 (hardened and polished*)	35x16 (hardened and polished*)
Translation	4 roller slides (each: 3 Ø40* rollers)	4 Ø75* V-shaped steel rollers
E-chain inside dimensions	115x45 [mm]	75x45 [mm]
Pinion diameter	63 [mm]	44 [mm]

Weights	Y Axis	Z Axis
"Base" portal ($y_{stroke}=z_{stroke}=0$)		$M_{base} = 97$ [Kg] approx.
Carriage (plate+roller slides)		$M_{slide} = 48$ [Kg] approx.
1000mm beam (incl.linear guide rails and rack)	$q_y = 32$ [Kg] approx.	$q_z = 20$ [Kg] approx.

To calculate the portal total weight please use the following formula:

$M_{tot} = M_{base} + [q_y \cdot y_{stroke}/1000] + [q_z \cdot z_{stroke}/1000]$ where x_{stroke} is expressed in mm.

(*) For any further information please see the Tecline Components catalogue.

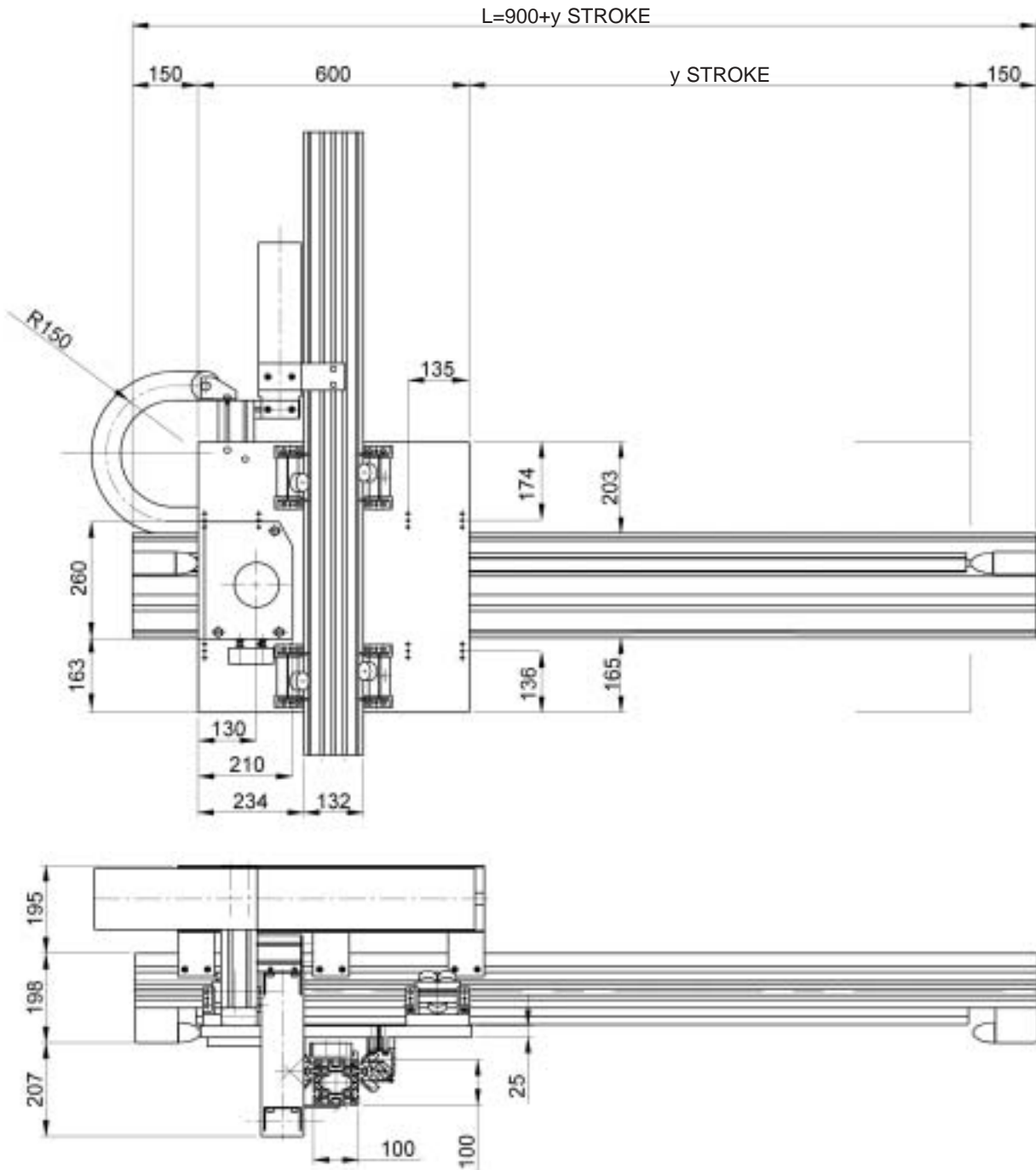

All reported data refer to indicative values to determine the appropriate portal

Performances	Y Axis	Z Axis
Max. load	200[Kg]	100[Kg]
Max. translation speed	5 [m/s]	2 [m/s]
Repositioning accuracy	±0,5 [mm]	±0,5 [mm]
Max. stroke	47 [m]	3 [m]
Max. bay	12 [m]	-

Each mentioned value must be considered as the max. performance of the item it refers to.
For a correct scaling please fill out the form at page 5 and send it to our Technical Service.

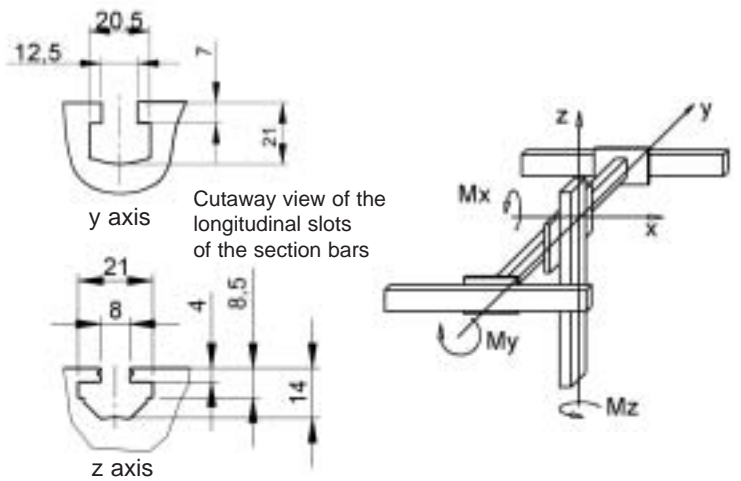
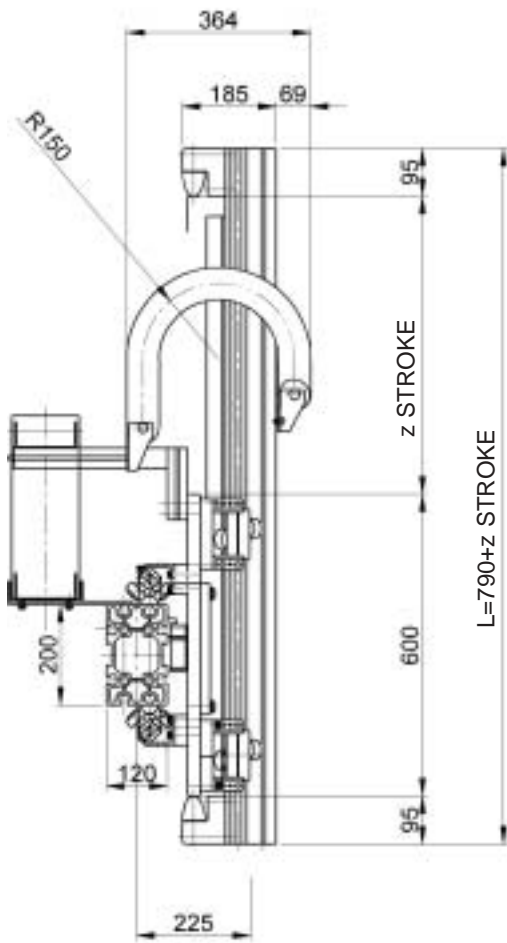

Construction data	Y Axis	Z Axis
Beam	Valyda (see page 8/9)*	MA1-5 (see page 8/9)*
Rack	30x30 [mm] - module 3	30x30 [mm] - module 3
Linear guide rail	35x16 (hardened and polished*)	35x16 (hardened and polished*)
Translation	4 roller slides (each: 3 Ø40* rollers)	4 roller slides (each: 2 Ø40* rollers)
E-chain inside dimensions	115x45 [mm]	75x45 [mm]
Pinion diameter	63 [mm]	63 [mm]

Weights	Y Axis	Z Axis
"Base" portal ($y_{stroke}=z_{stroke}=0$)	$M_{base} = 107$ [Kg] approx.	
Carriage (plate+roller slides)	$M_{slide} = 51$ [Kg] approx.	
1000mm beam (incl.linear guide rails and rack)	$q_y = 37$ [Kg] approx	$q_z = 25$ [Kg] approx

To calculate the portal total weight please use the following formula:

$$M_{tot} = M_{base} + [q_y \cdot y_{stroke} / 1000] + [q_z \cdot z_{stroke} / 1000]$$

Where x_{stroke} is expressed in mm.

(*) For any further information please see the Tecline Components catalogue.

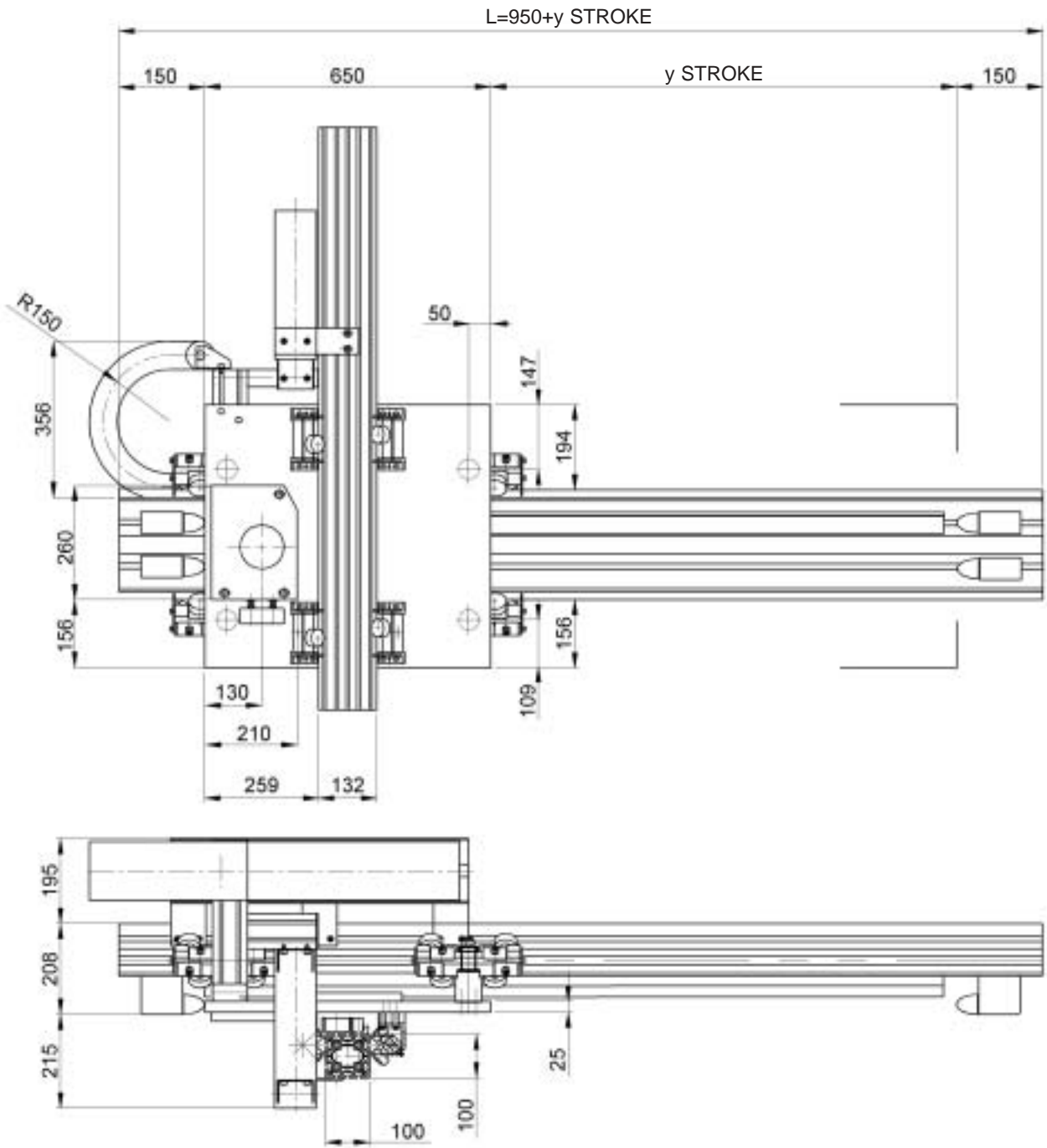

All reported data refer to indicative values to determine the appropriate portal

Performances	Y Axis	Z Axis
Max. load	300[Kg]	100[Kg]
Max. translation speed	5 [m/s]	2 [m/s]
Repositioning accuracy	±0,5 [mm]	±0,5 [mm]
Max. stroke	47 [m]	3 [m]
Max. bay	12 [m]	-

Each mentioned value must be considered as the max. performance of the item it refers to.

For a correct scaling please fill out the form at page 5 and send it to our Technical Service.

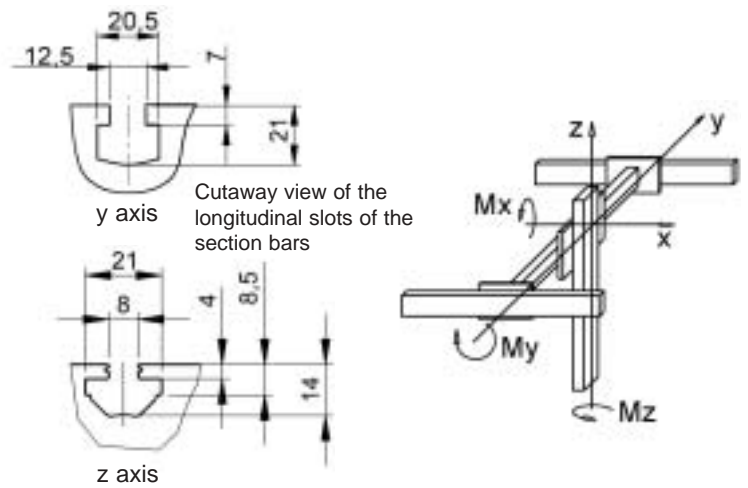
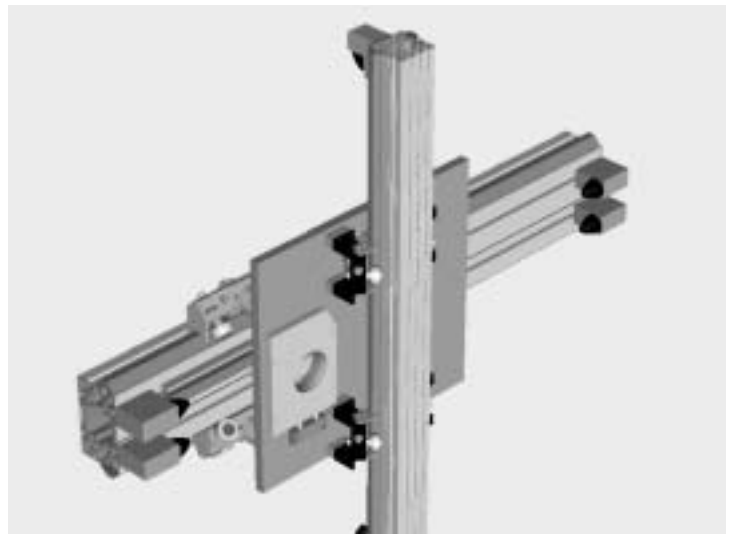
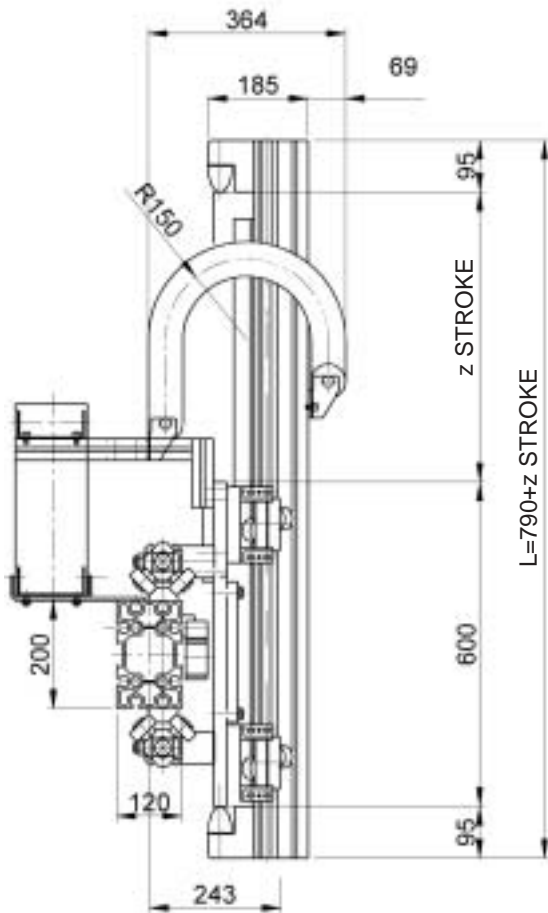

Construction data	Y Axis	Z Axis
Beam	Valyda (see page 8/9)*	MA1-5 (see page 8/9)*
Rack	40x40 [mm] - module 4	30x30 [mm] - module 3
Linear guide rail	55x25 (hardened and polished*)	35x16 (hardened and polished*)
Translation	4 roller slides (each: 4 Ø52* rollers)	4 roller slides (each: 2 Ø40* rollers)
E-chain inside dimensions	115x45 [mm]	75x45 [mm]
Pinion diameter	68 [mm]	63 [mm]

Weights	Y Axis	Z Axis
"Base" portal ($y_{stroke}=z_{stroke}=0$)	$M_{base} = 137$ [Kg] approx.	
Carriage (plate+roller slides)	$M_{slide} = 69$ [Kg] approx.	
1000mm beam (incl.linear guide rails and rack)	$q_y = 49$ [Kg] approx	$q_z = 25$ [Kg] approx

To calculate the portal total weight please use the following formula:

$$M_{tot} = M_{base} + [q_y \cdot y_{stroke}/1000] + [q_z \cdot z_{stroke}/1000]$$

where x_{stroke} is expressed in mm..

(*) For any further information please see the Tecline Components catalogue.

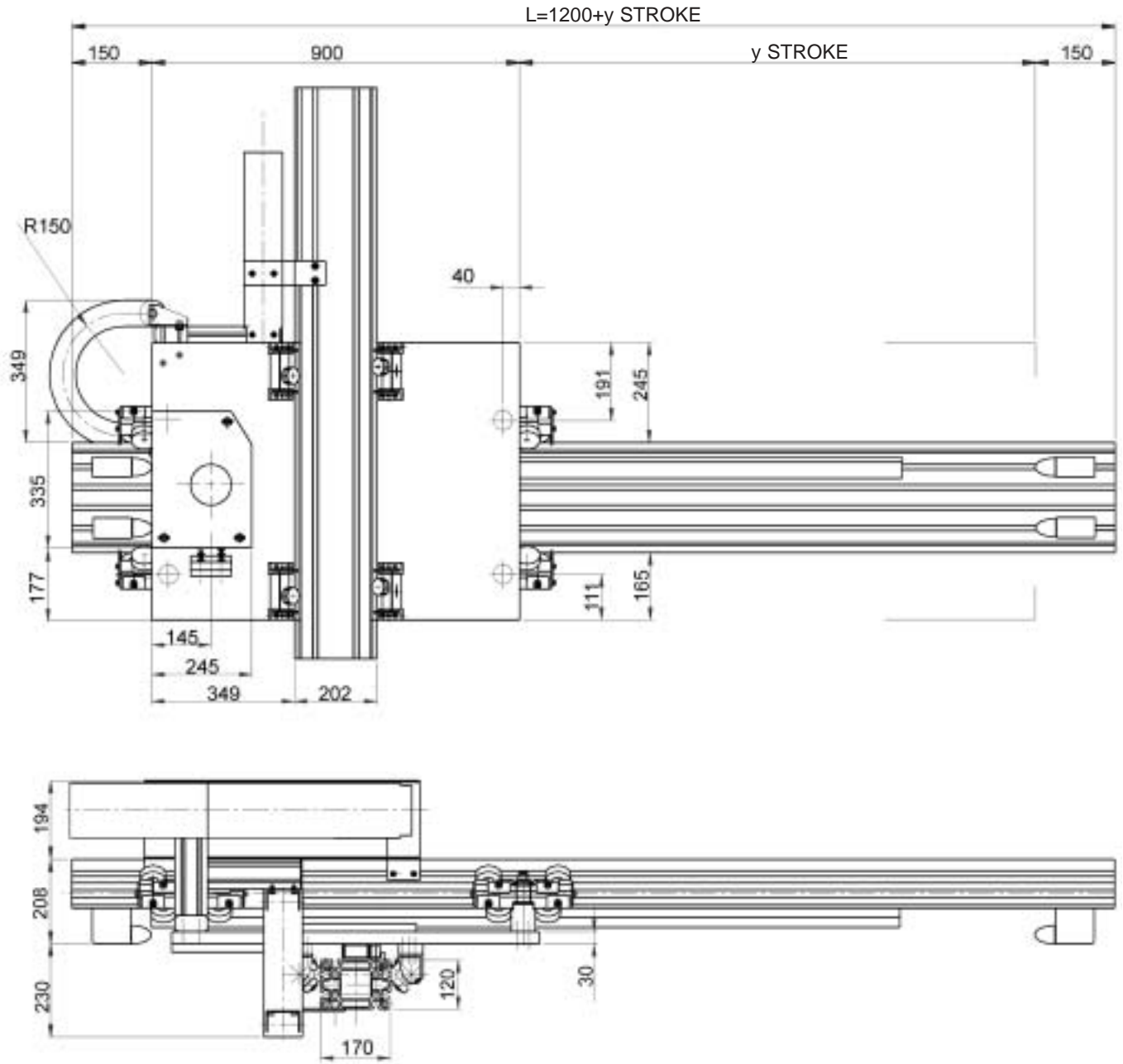

All reported data refer to indicative values to determine the appropriate portal

Performances	Y Axis	Z Axis
Max. load	300[Kg]	200[Kg]
Max. translation speed	5 [m/s]	2 [m/s]
Repositioning accuracy	±0,5 [mm]	±0,5 [mm]
Max. stroke	46,8 [m]	3 [m]
Max. bay	12 [m]	-

Each mentioned value must be considered as the max. performance of the item it refers to.

For a correct scaling please fill out the form at page 5 and send it to our Technical Service.

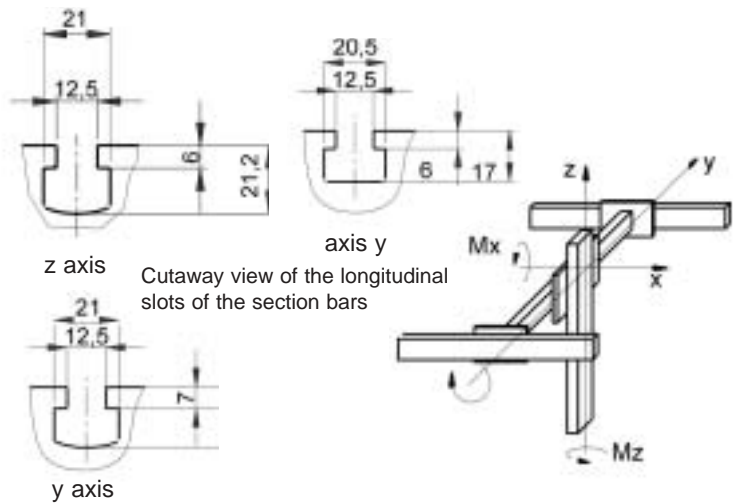
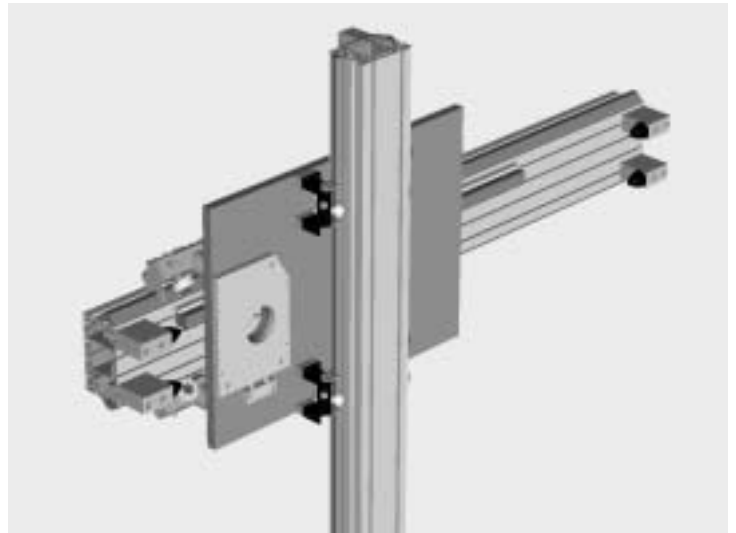
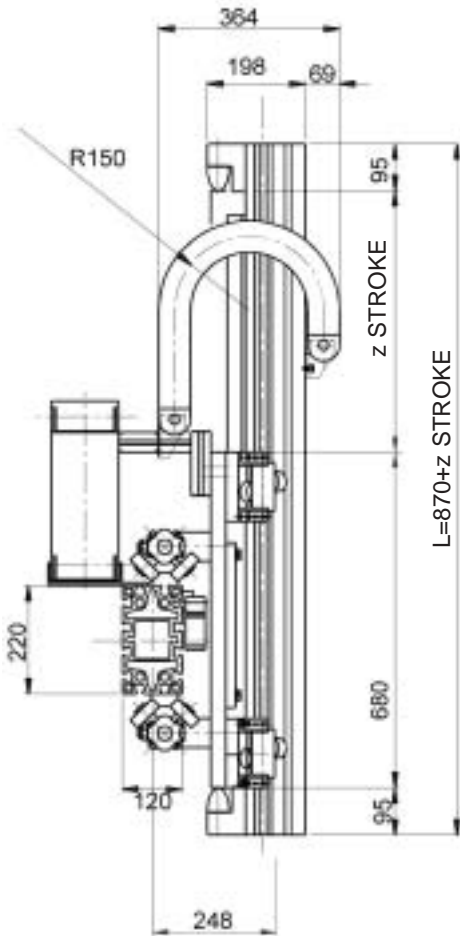

Construction data	Y Axis	Z Axis
Beam	Logyca (see page 8/9)*	Statyca (see page 8/9)*
Rack	40x40 [mm] - module 4	30x30 [mm] - module 3
Linear guide rail	55x25 (hardened and polished*)	35x16 (hardened and polished*)
Translation	4 roller slides (each: 4 Ø62* rollers)	4 roller slides (each: 2 Ø40* rollers)
E-chain inside dimensions	usable section 175x45	usable section 75x45
Pinion diameter	68 [mm]	63 [mm]

Weights	Y Axis	Z Axis
"Base" portal ($y_{stroke}=z_{stroke}=0$)	$M_{base} = 194$ [Kg] approx.	
Carriage (plate+roller slides)	$M_{slide} = 99$ [Kg] approx.	
1000mm beam (incl.linear guide rails and rack)	$q_y = 53$ [Kg] approx	$q_z = 32$ [Kg] approx

To calculate the portal total weight please use the following formula:

$$M_{tot} = M_{base} + [q_y \cdot y_{stroke} / 1000] + [q_z \cdot z_{stroke} / 1000]$$

where stroke is expressed in mm.

(*) For any further information please see the Tecline Components catalogue.

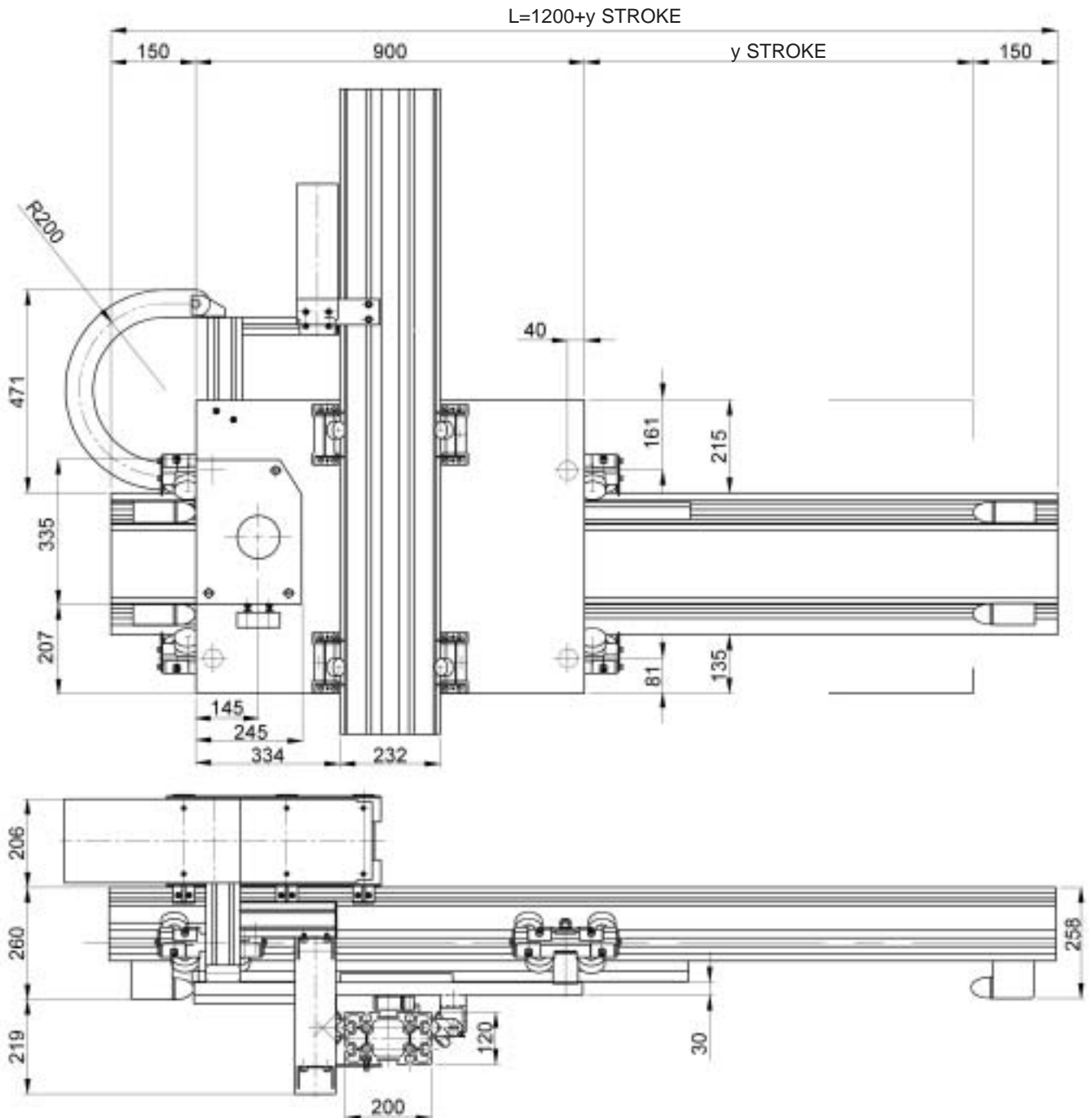

All reported data refer to indicative values to determine the appropriate portal

Performances	Y Axis	Z Axis
Max. load	400[Kg]	200[Kg]
Max. translation speed	5 [m/s]	2 [m/s]
Repositioning accuracy	±0,5 [mm]	±0,5 [mm]
Max. stroke	46,8 [m]	3 [m]
Max. bay	12 [m]	-

Each mentioned value must be considered as the max. performance of the item it refers to.

For a correct scaling please fill out the form at page 5 and send it to our Technical Service.

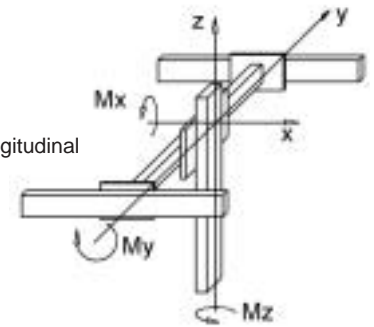
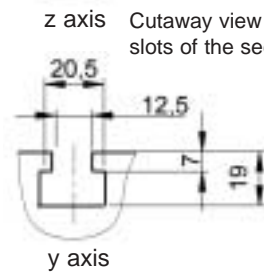
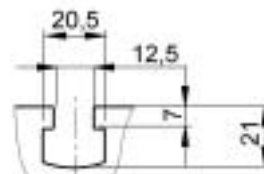
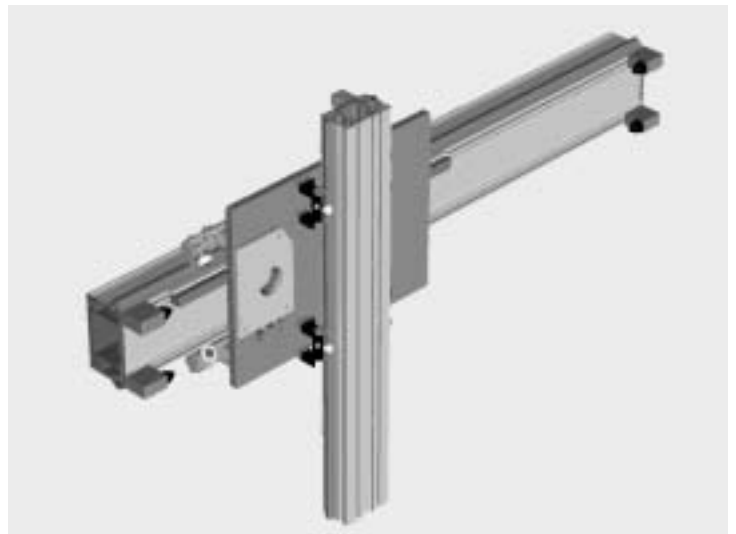
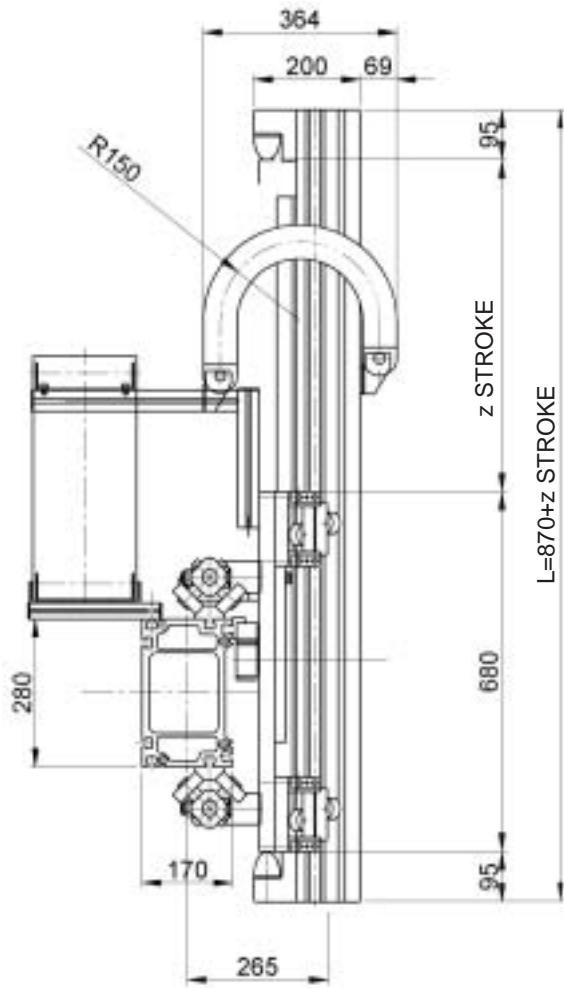

Construction data	Y Axis	Z Axis
Beam	Pratyca (see page 8/9)*	Valyda (see page 8/9)*
Rack	40x40 [mm] - module 4	30x30 [mm] - module 3
Linear guide rail	55x25 (hardened and polished*)	35x16 (hardened and polished*)
Translation	4 roller slides (each: 4 Ø62* rollers)	4 roller slides (each: 4 Ø40* rollers)
E-chain inside dimensions	175x45 [mm]	75x45 [mm]
Pinion diameter	68 [mm]	63 [mm]

Weights	Y Axis	Z Axis
"Base" portal ($y_{stroke}=z_{stroke}=0$)		$M_{base} = 219$ [Kg] approx.
Carriage (plate+roller slides)		$M_{slide} = 101$ [Kg] approx.
1000mm beam(incl.linear guide rails and rack)	$q_y = 67$ [Kg] approx.	$q_z = 37$ [Kg] approx.

To calculate the portal total weight please use the following formula:

$$M_{tot} = M_{base} + [q_y \cdot y_{stroke} / 1000] + [q_z \cdot z_{stroke} / 1000]$$

where stroke is expressed in mm.

(*) For any further information please see the Tecline Components catalogue.

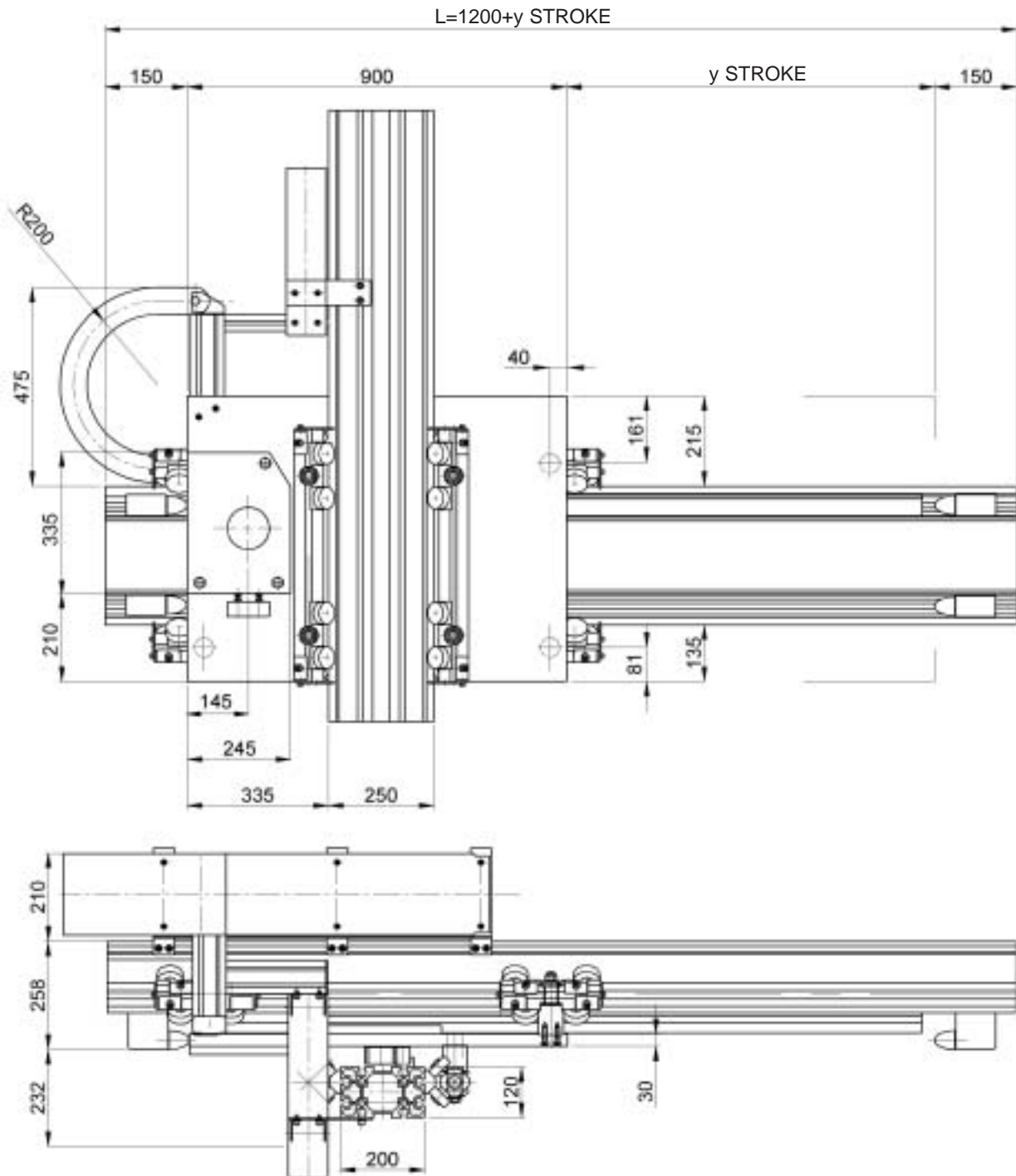

All reported data refer to indicative values to determine the appropriate portal

Performances	Y Axis	Z Axis
Max. load	200[Kg]	400[Kg]
Max. translation speed	5 [m/s]	2 [m/s]
Repositioning accuracy	$\pm 0,5$ [mm]	$\pm 0,5$ [mm]
Max. stroke	46,8 [m]	4 [m]
Max. bay	12 [m]	-

Each mentioned value must be considered as the max. performance of the item it refers to.

For a correct scaling please fill out the form at page 5 and send it to our Technical Service.

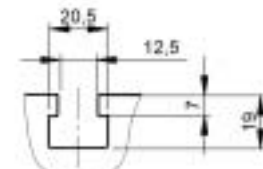
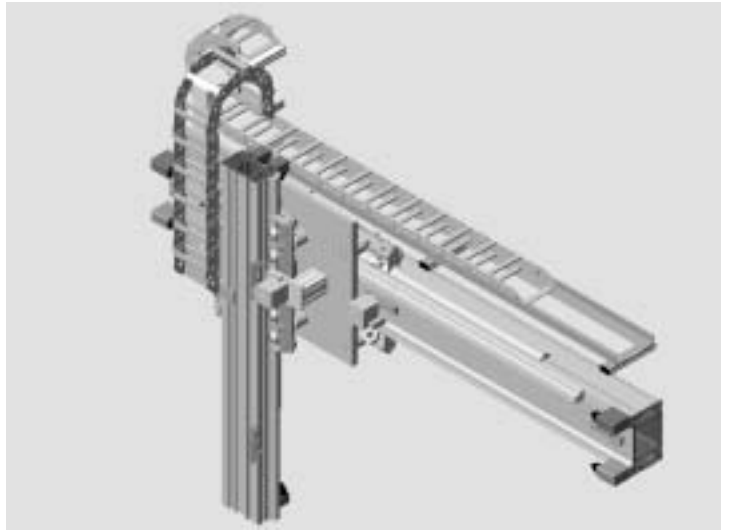
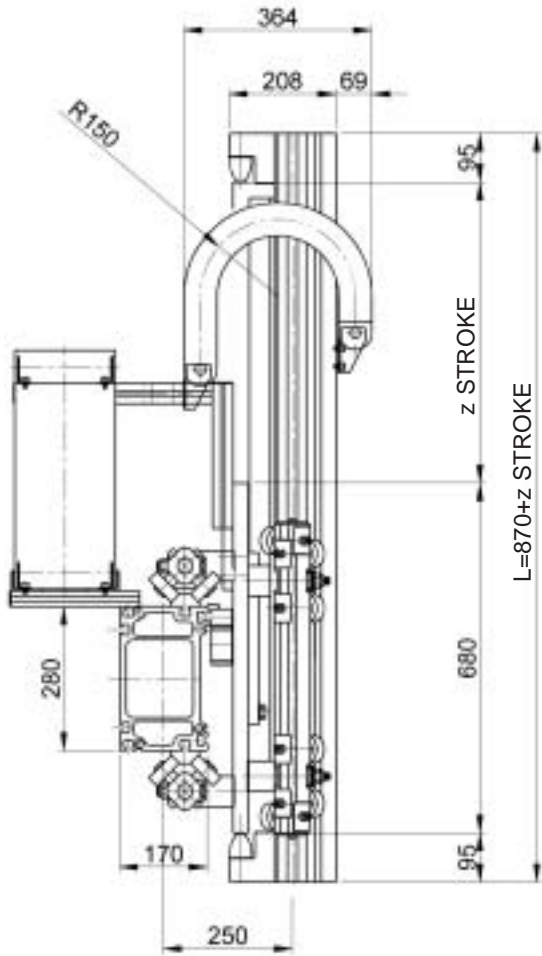

y axis Cutaway view of the longitudinal slots of the section bars

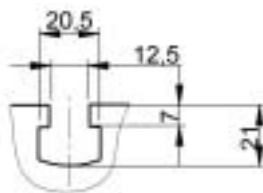

z axis

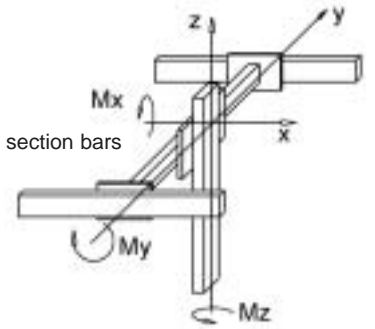

Construction data	Y Axis	Z Axis
Beam	Pratyca (see page 8/9)*	Valyda (see page 8/9)*
Rack	40x40 [mm] - module 4	40x40 [mm] - module 4
Linear guide rail	55x25 (hardened and polished*)	55x25 (hardened and polished*)
Translation	4 roller slides (each: 4 Ø62* rollers)	2 roller slides (each: 6 Ø52* rollers)
E-chain inside dimensions	175x45 [mm]	75x45 [mm]
Pinion diameter	68 [mm]	68 [mm]

Weights	Y Axis	Z Axis
"Base" portal ($y_{stroke}=z_{stroke}=0$)	$M_{base} = 242$ [Kg] approx.	
Carriage (plate+roller slides)	$M_{slide} = 117$ [Kg] approx.	
1000mm beam (incl.linear guide rails and rack)	$q_Y = 67$ [Kg] approx	$q_Z = 49$ [Kg] approx

To calculate the portal total weight please use the following formula:

$$M_{tot} = M_{base} + [q_y \cdot y_{stroke} / 1000] + [q_z \cdot z_{stroke} / 1000]$$

where stroke is expressed in mm.

(*) For any further information please see the Tecline Components catalogue.

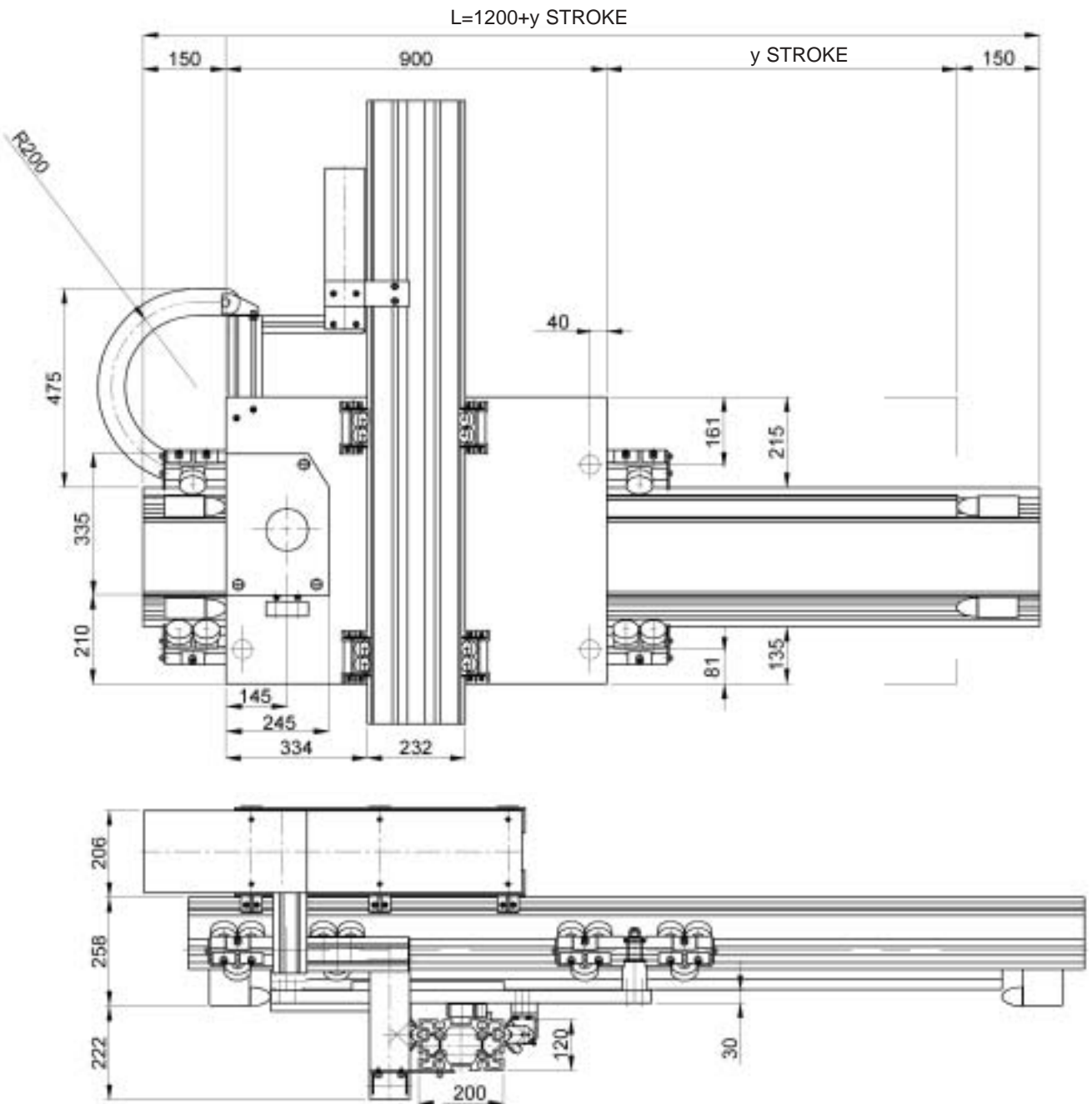

All reported data refer to indicative values to determine the appropriate portal

Performances	Y Axis	Z Axis
Max. load	500[Kg]	300[Kg]
Max. translation speed	5 [m/s]	2 [m/s]
Repositioning accuracy	±0,5 [mm]	±0,5 [mm]
Max. stroke	46,8 [m]	3 [m]
Max. bay	12 [m]	-

Each mentioned value must be considered as the max. performance of the item it refers to.

For a correct scaling please fill out the form at page 5 and send it to our Technical Servicer.

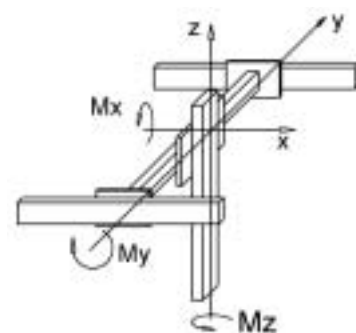
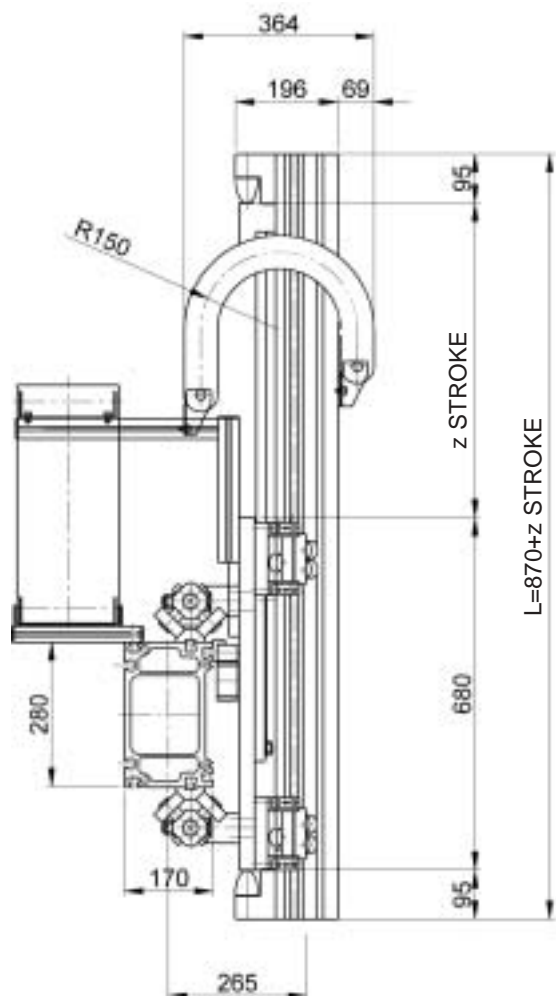

Construction data	Y Axis	Z Axis
Beam	Pratyca (see page. 8/9)*	Valyda (see page 8/9)*
Rack	40x40 [mm] - module 4	30x30 [mm] - module 3
Linear guide rail	55x25 (hardened and polished*)	35x16 (hardened and polished*)
Translation	4 roller slides (each: 6 Ø62* rollers)	4 roller slides (each: 2 Ø40* rollers)
E-chain inside dimensions	175x45 [mm]	75x45 [mm]
Pinion diameter	68 [mm]	63 [mm]

Weights	Y Axis	Z Axis
"Base" portal ($y_{stroke}=z_{stroke}=0$)	$M_{base} = 228$ [Kg] approx.	
Carriage (plate+roller slides)	$M_{slide} = 110$ [Kg] approx.	
1000mm beam (incl.linear guide rails and rack)	$q_y = 67$ [Kg] approx.	$q_z = 37$ [Kg] approx.

To calculate the portal total weight please use the following formula:

$M_{tot} = M_{slide} + [q_y \cdot y_{stroke}/1000] + [q_z \cdot z_{stroke}/1000]$ where stroke is expressed in mm.

(*) For any further information please see the Tecline Components catalogue.

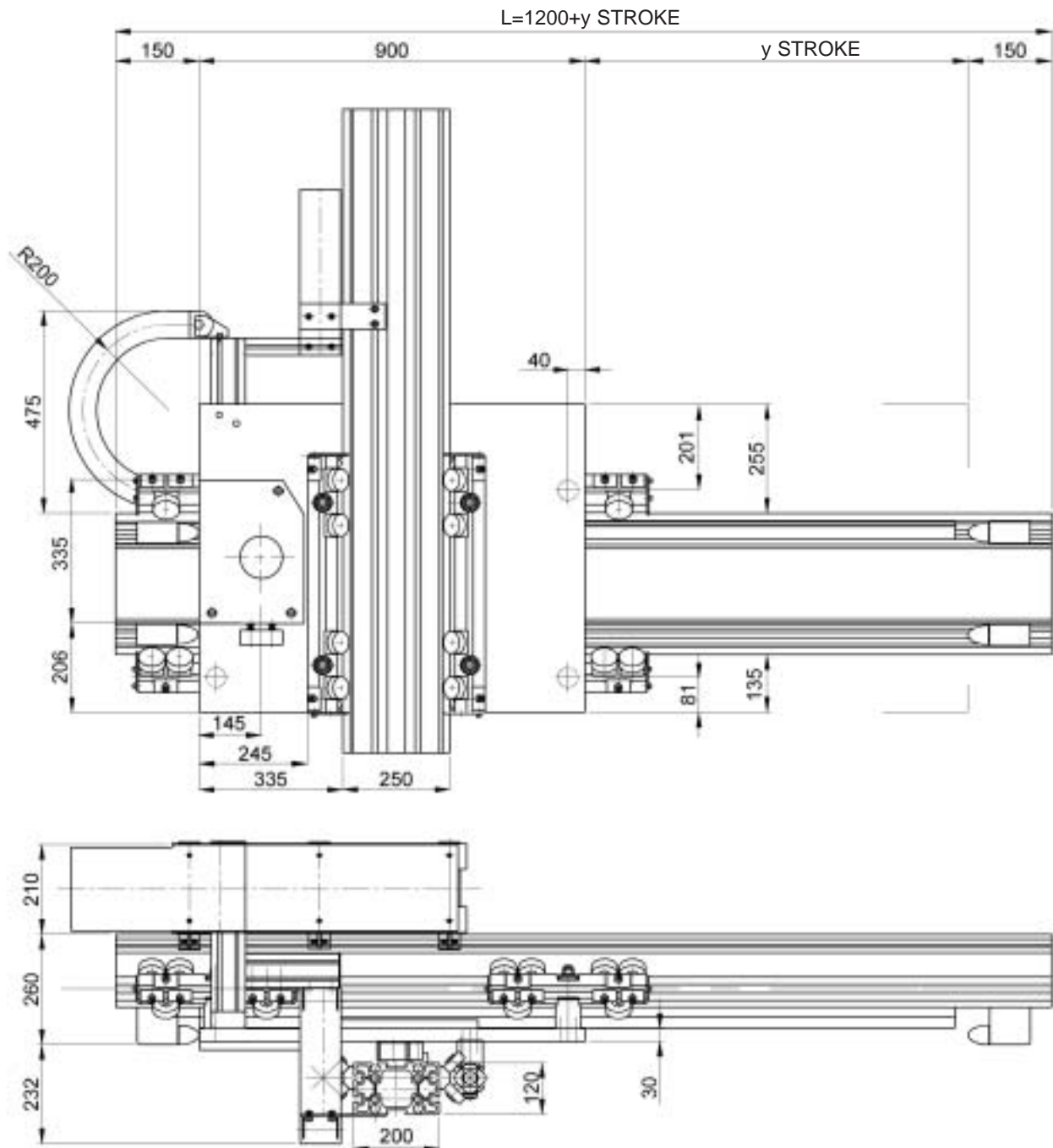

All reported data refer to indicative values to determine the appropriate portal

Performances	Y Axis	Z Axis
Max. load	200[Kg]	600[Kg]
Max. translation speed	5 [m/s]	2 [m/s]
Repositioning accuracy	±0,5 [mm]	±0,5 [mm]
Max. stroke	46,8 [m]	4 [m]
Max. bay	12 [m]	-

Each mentioned value must be considered as the max. performance of the item it refers to.

For a correct scaling please fill out the form at page 5 and send it to our Technical Service.

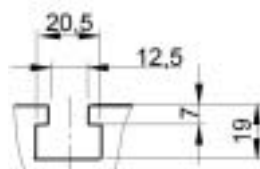
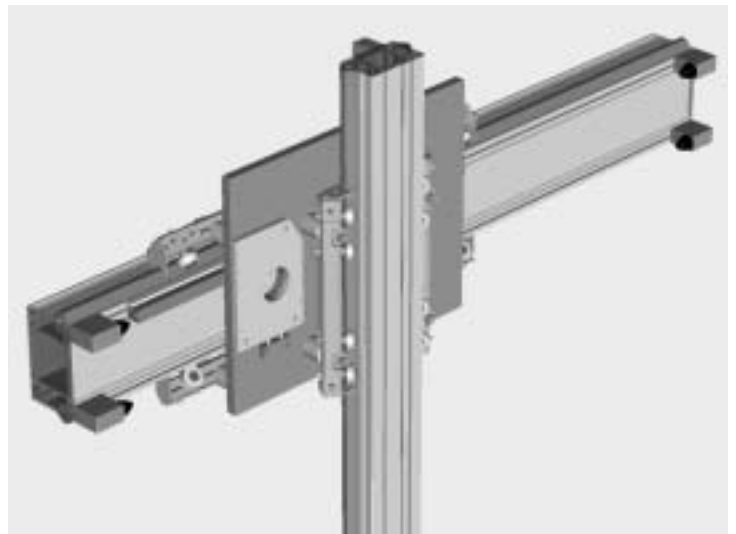
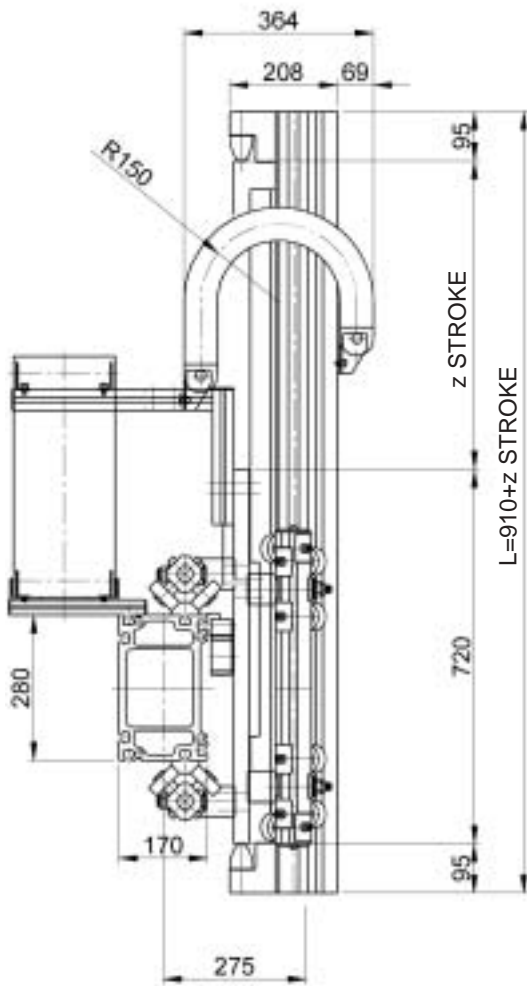

y axis

Cutaway view of the slots of the section bars

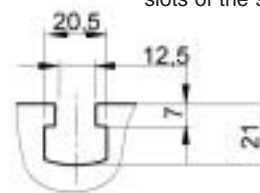

z axis

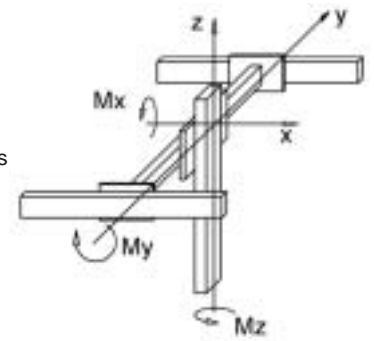

Construction data	Y Axis	Z Axis
Beam	Pratyca (see page 8/9)*	Valyda (see page 8/9)*
Rack	40x40 [mm] - module 4	40x40 [mm] - module 4
Linear guide rail	55x25 (hardened and polished*)	55x25 (hardened and polished*)
Translation	4 roller slides (each: 6 Ø62* rollers)	2 roller slides (each: 6 Ø52* rollers)
E-chain inside dimensions	175x45 [mm]	75x45 [mm]
Pinion diameter	68 [mm]	68 [mm]

Weights	Y Axis	Z Axis
"Base" portal ($y_{stroke}=z_{stroke}=0$)	$M_{base} = 257$ [Kg] approx.	
Carriage (plate+roller slides)	$M_{slide} = 129$ [Kg] approx.	
1000mm beam (incl.linear guide rails and rack)	$q_y = 67$ [Kg] approx.	$q_z = 49$ [Kg] approx.

To calculate the portal total weight please use the following formula:

$M_{tot} = M_{base} + [q_y \cdot y_{stroke}/1000] + [q_z \cdot z_{stroke}/1000]$ where stroke is expressed in mm.

(*) For any further information please see the Tecline Components catalogue.

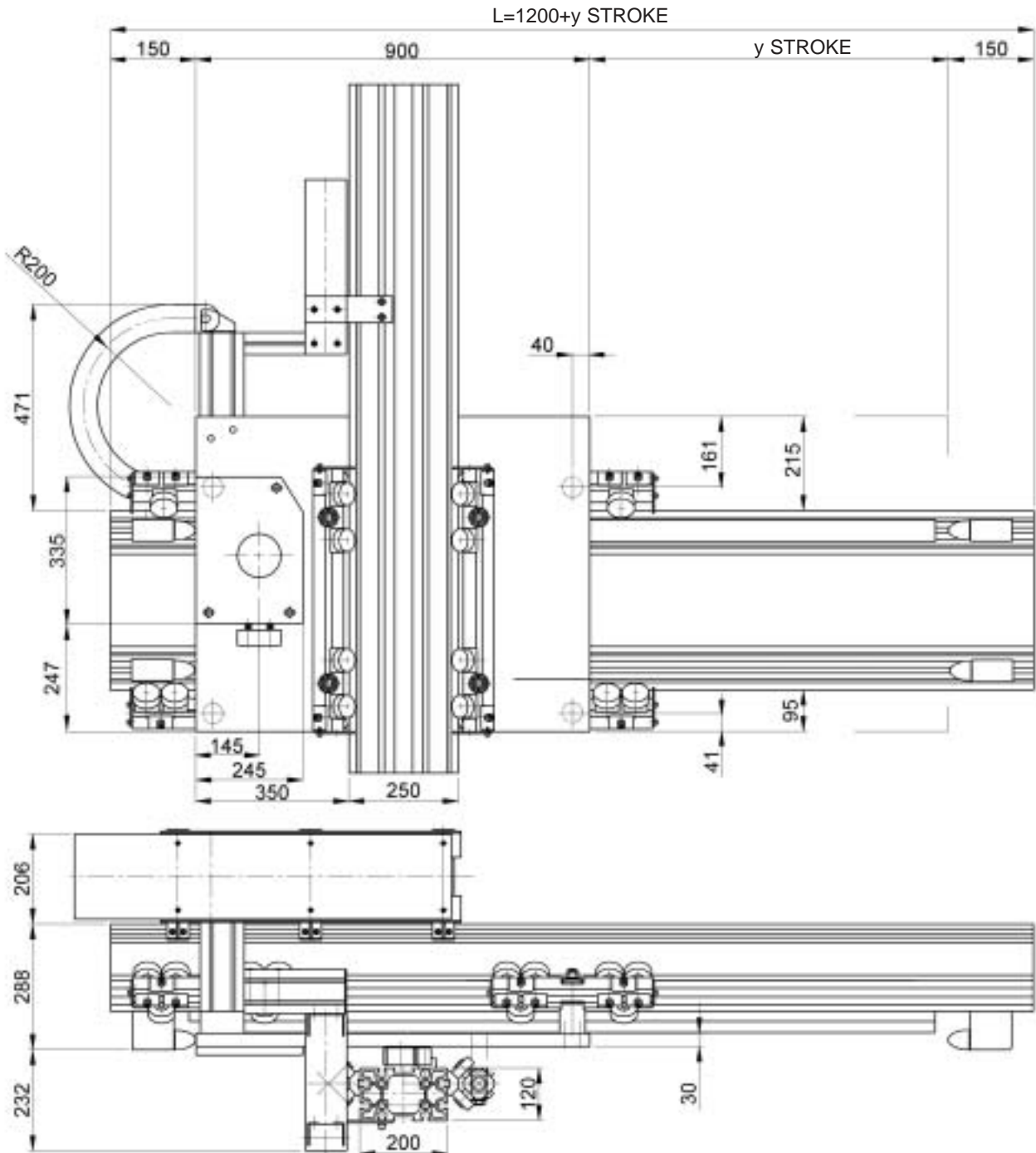

All reported data refer to indicative values to determine the appropriate portal

Performances	Y Axis	Z Axis
Max. load	400[Kg]	600[Kg]
Max. translation speed	5 [m/s]	2 [m/s]
Repositioning accuracy	$\pm 0,5$ [mm]	$\pm 0,5$ [mm]
Max. stroke	46,8 [m]	4 [m]
Max. bay	12 [m]	-

Each mentioned value must be considered as the max. performance of the item it refers to.
For a correct scaling please fill out the form at page 5 and send it to our Technical Service.

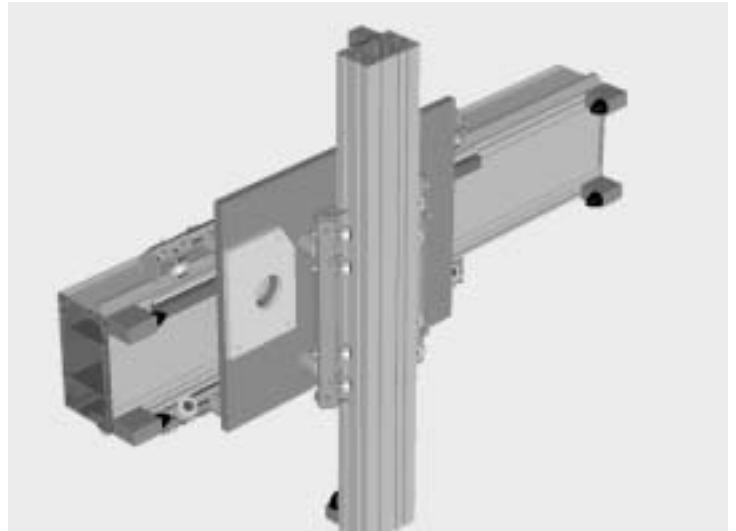
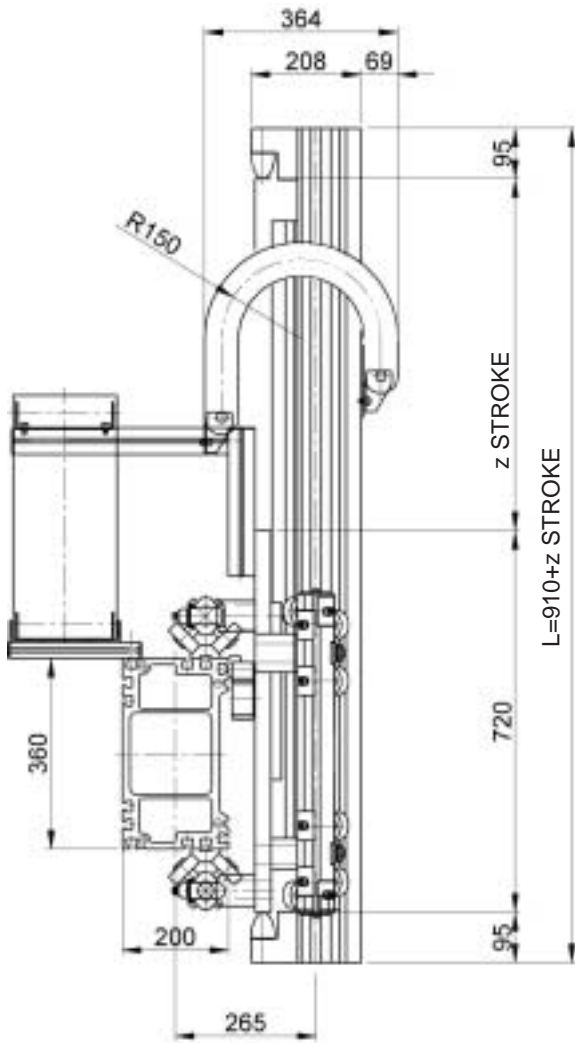

Cutaway view of the slot of the section bar

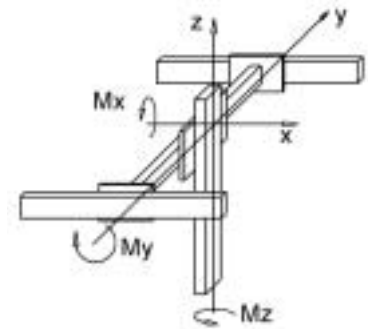
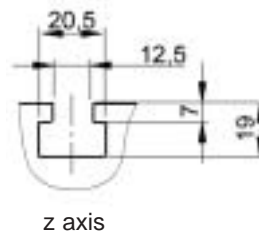

Construction data	Y Axis	Z Axis
Beam	Solyda (see page 8/9)*	Valyda (see page 8/9)*
Rack	40x40 [mm] - module 4	40x40 [mm] - module 4
Linear guide rail	55x25 (hardened and polished*)	55x25 (hardened and polished*)
Translation	4 roller slides (each: 6 Ø62* rollers)	2 roller slides (each: 6 Ø52* rollers)
E-chain inside dimensions	175x45 [mm]	75x45 [mm]
Pinion diameter	68 [mm]	68 [mm]

Weights	Y Axis	Z Axis
"Base" portal ($y_{stroke}=z_{stroke}=0$)	$M_{base} = 280$ [Kg] approx.	
Carriage (plate+roller slides)	$M_{slide} = 129$ [Kg] approx.	
1000mm beam (incl.linear guide rails and rack)	$q_Y = 86$ [Kg] approx.	$q_Z = 49$ [Kg] approx.

To calculate the portal total weight please use the following formula:

$M_{tot} = M_{base} + [q_y \cdot y_{stroke}/1000] + [q_z \cdot z_{stroke}/1000]$ where stroke is expressed in mm.

(*) For any further information please see the Tecline Components catalogue.

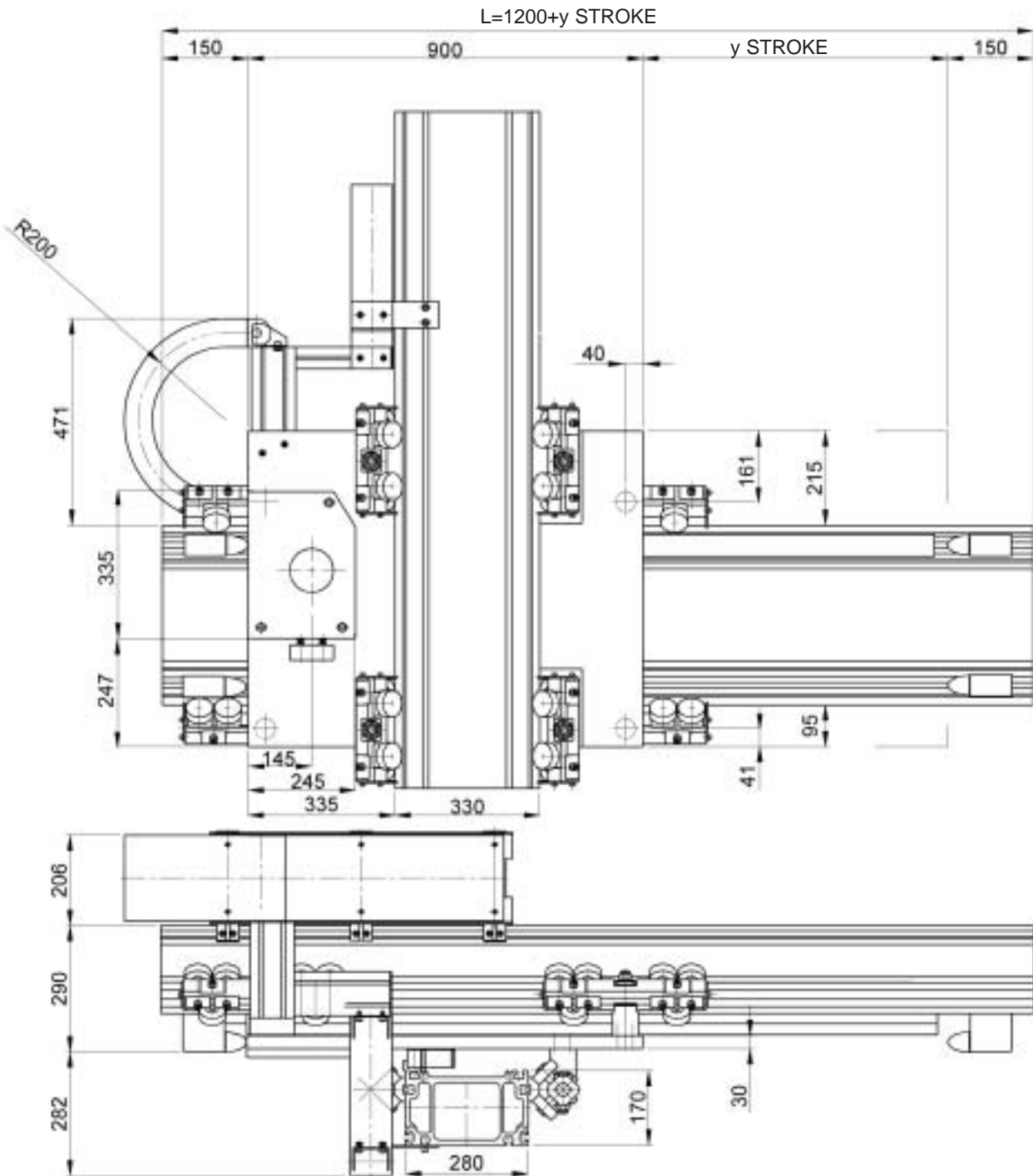

All reported data refer to indicative values to determine the appropriate portal

Performances	Y Axis	Z Axis
Max. load	200[Kg]	800[Kg]
Max. translation speed	5 [m/s]	2 [m/s]
Repositioning accuracy	±0,5 [mm]	±0,5 [mm]
Max. stroke	46,8 [m]	3 [m]
Max. bay	12 [m]	-

Each mentioned value must be considered as the max. performance of the item it refers to.
For a correct scaling please fill out the form at page 5 and send it to our Technical Service.

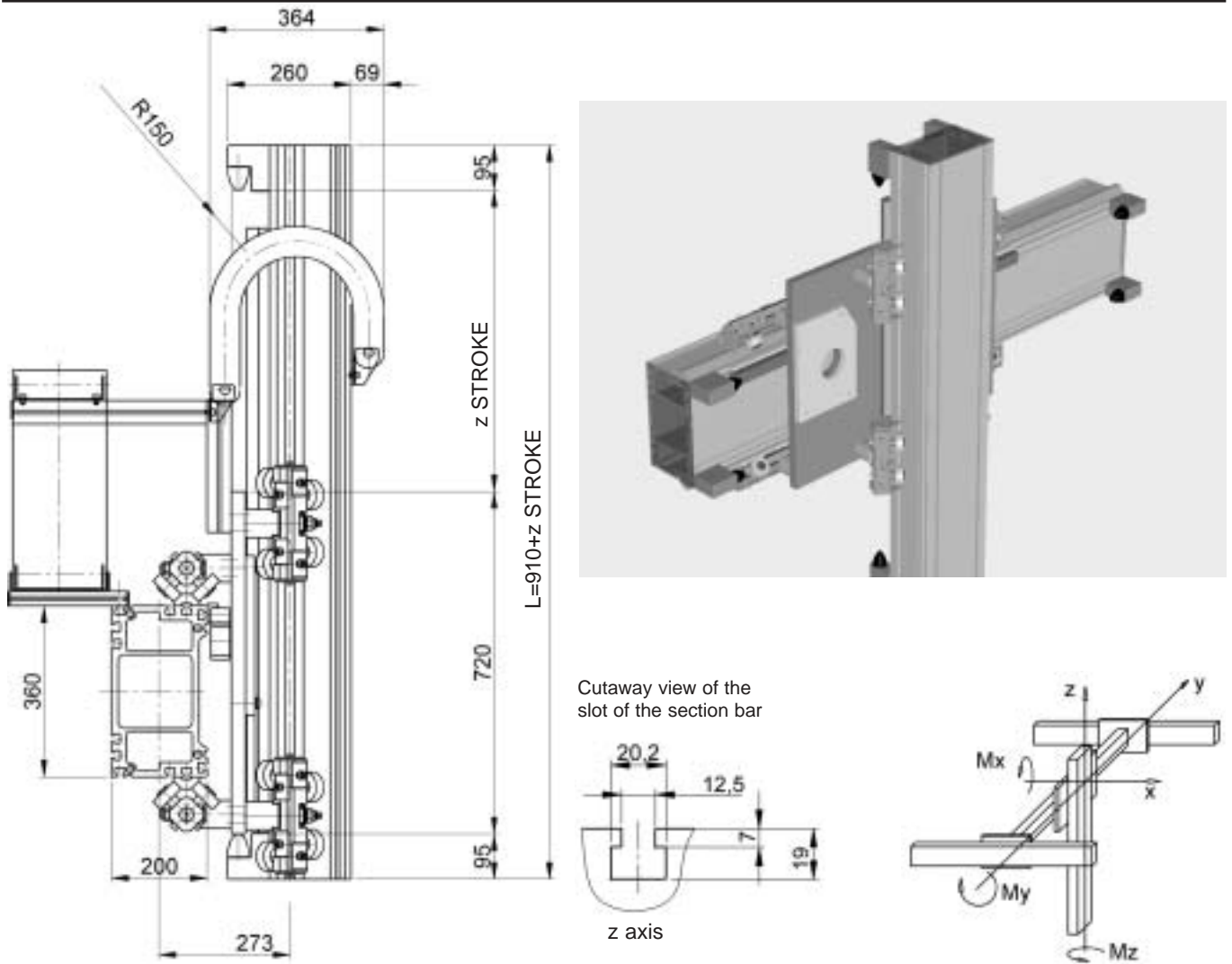

Construction data	Y Axis	Z Axis
Beam	Solyda (see page 8/9)*	Pratycza (see page 8/9)*
Rack	40x40 [mm] - module 4	40x40 [mm] - module 4
Linear guide rail	55x25 (hardened and polished*)	55x25 (hardened and polished*)
Translation	4 roller slides (each: 6 Ø62* rollers)	4 roller slides (each: 6 Ø62* rollers)
E-chain inside dimensions	175x45 [mm]	75x45 [mm]
Pinion diameter	68 [mm]	68 [mm]

Weights	Y Axis	Z Axis
"Base" portal ($y_{stroke}=z_{stroke}=0$)	$M_{base} = 284$ [Kg] approx.	
Carriage (plate+roller slides)	$M_{slide} = 130$ [Kg] approx.	
1000mm beam (incl.linear guide rails and rack)	$q_Y = 86$ [Kg] approx.	$q_Z = 67$ [Kg] approx.

To calculate the portal total weight please use the following formula:

$M_{tot} = M_{base} + [q_y \cdot y_{stroke}/1000] + [q_z \cdot z_{stroke}/1000]$ where stroke is expressed in mm.

(*) For any further information please see the Tecline Components catalogue.

Nuts and plates

Alignment nuts and plates

Scale 1 : 1

Code 209.1855

Alignment nut

- "V"-shaped guide rails: 35x16
- Profile with 12.5mm slot

Code 209.0298

"T" alignment nut

- "V"-shaped guide rails: 35x16
- Profile: MA 1-5, E 01-4

Code 209.0479

Alignment feather

- "V"-shaped guide rails: 55x25
- Profile: MA 1-5, E 01-4

Code 209.0480

Alignment feather

- "V"-shaped guide rails: 55x25
- Profile with 12,5mm slot

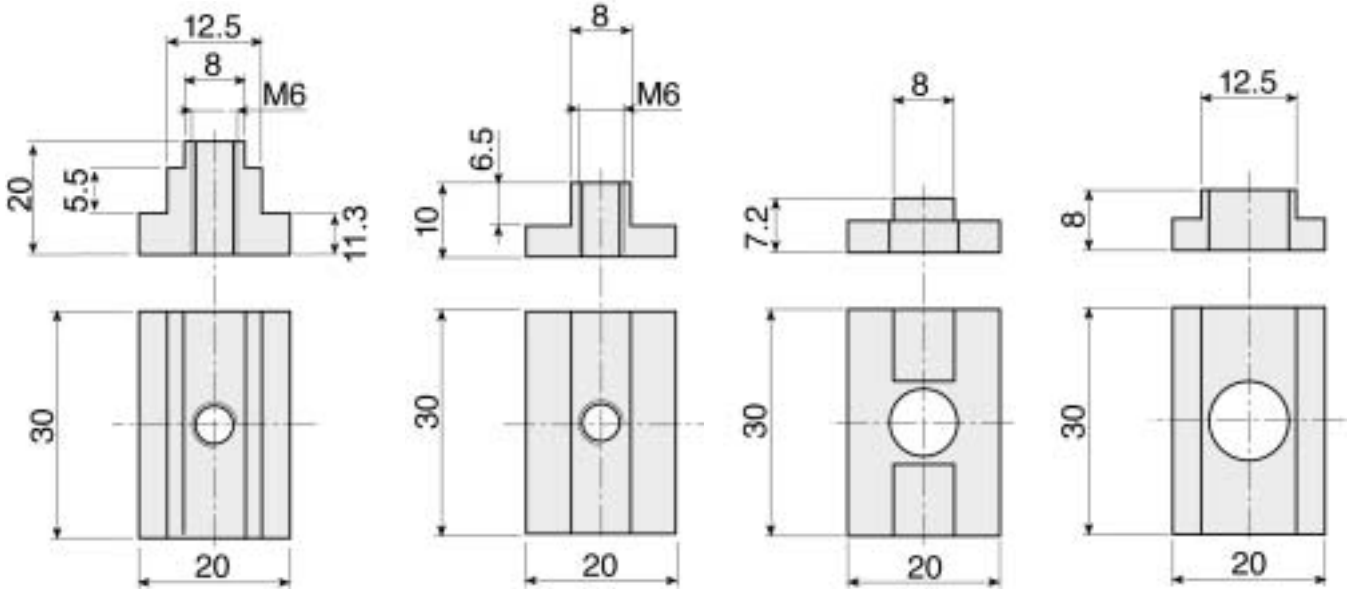

Assembling Diagrams

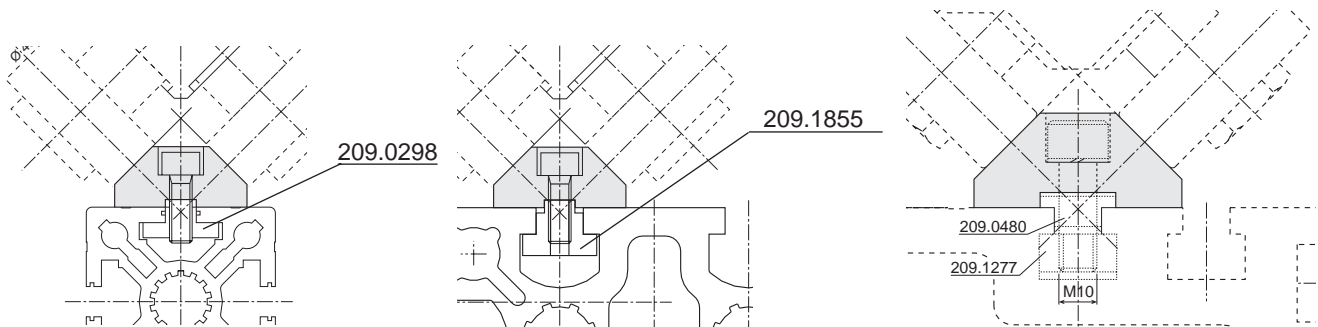

Alignment plate. Frontally insertable in 12.5mm slots after assembling

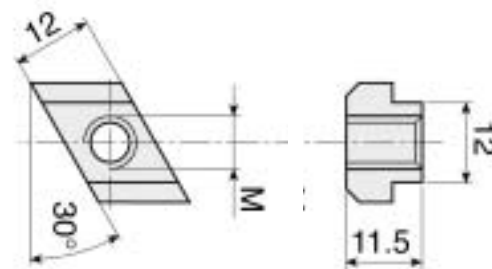

Thread	Code
M5	215.1768
M6	215.1769
M8	215.1770
M10	215.2124

Alignment plate for 12.5mm slots

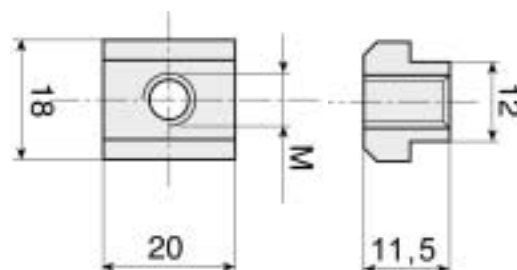

Thread	Code
M5	215.1771
M6	215.1772
M8	215.1773
M10	215.2125

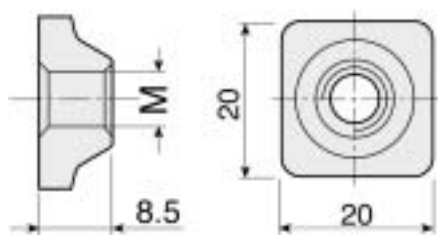

Thread	Code
M6	209.1202
M8	209.0467

Suitable also for profile code: MA 1-5, E 01-4.

Threaded half-round inserts

• A32-82

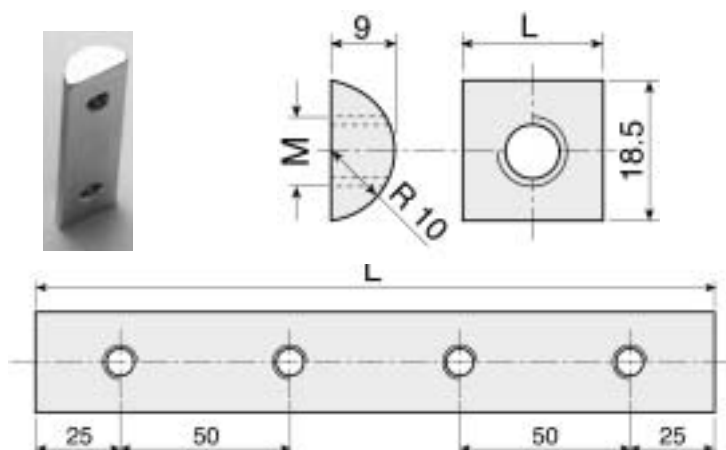

Threaded half-round plate. It can be fixed frontally through the 12.5mm slot

Suitable also for profile code: MA 1-5, E 01-4.

Thread	Type	L	Code
M6	1 hole plate	18.5	A32-61
M8	1 hole plate	18.5	A32-81
M10	1 hole plate	18.5	A32-91
M8	2 hole plate*	80	• A32-82
M8	3 hole plate*	150	A32-83
M8	4 hole plate*	200	A32-84
M8	5 hole plate*	250	A32-89
M8	6 hole plate*	300	A32-86
M8	hole plate*	350	A32-87

* Distance between hole centers: 50 mm

Threaded inserts

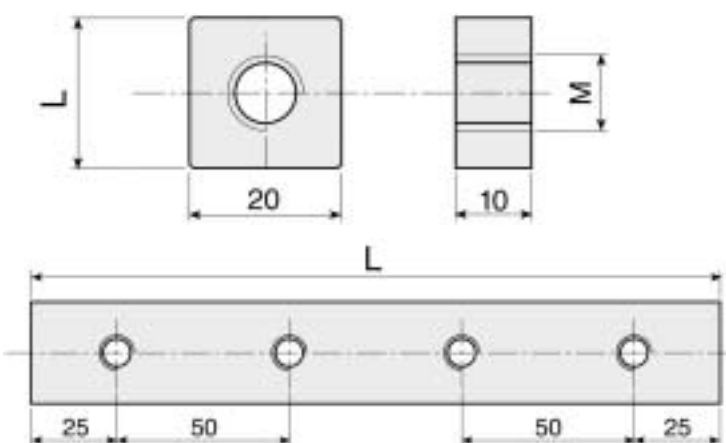

In the profiles with 12.5mm slots it is possible to use M12 (CH19) hexagonal-head screws as stud bolts.

Thread	TYPE slot 20x10	L	Code
M10	1 hole plate	40	215.0477
M12	1 hole plate	40	209.1281
M10	1 hole plate	20	209.1277
M10	2 hole plate*	80	209.1776
M10	3 hole plate*	150	209.1777
M10	4 hole plate*	200	209.1778
M10	5 hole plate*	250	209.1779
M10	6 hole plate*	300	209.1780
M10	7 hole plate*	350	209.1781

* Distance between hole centers: 50 mm

Threaded bushings



Thread	L	Code
M20/M6 Threaded bushing M20/M6 in.	25	207.1892
M20/M8 Threaded bushing M20/M8 in.	25	207.1893
M20/M10 Threaded bushing M20/M10 in.	25	207.1894
M20/M12 Threaded bushing M20/M12 in.	25	207.2288

Steel linear guide rails

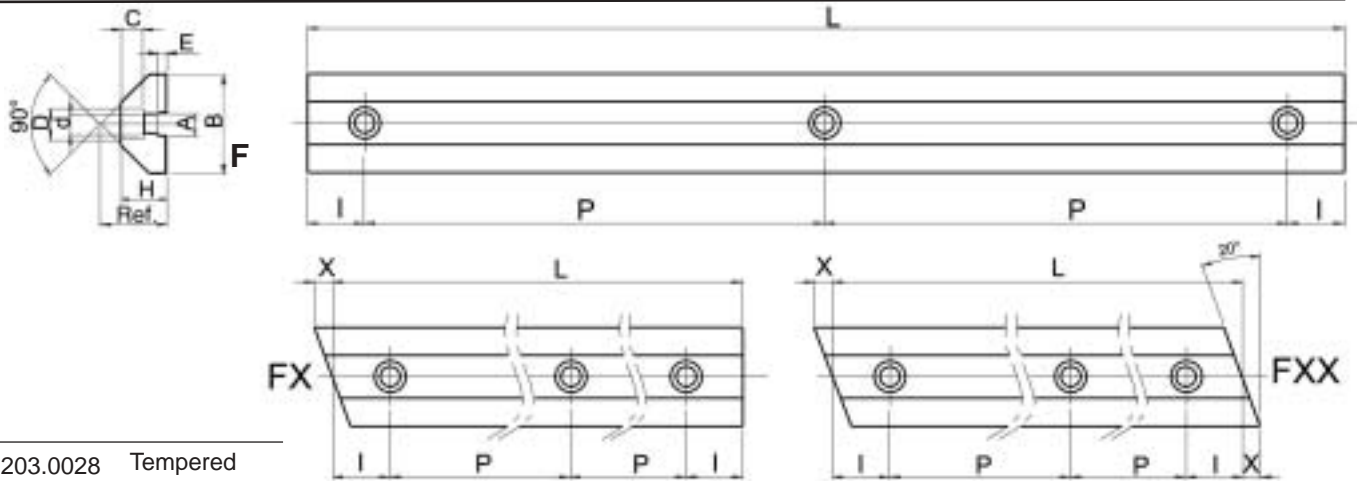

- 203.0028 Tempered
- 203.0122

- 203.0027 Induction
- 203.0423 hardened

CUT	L	I	P	Ref	A	B	E	H	D	d	C	1 CUT	X	2 CUTS
Straight												slanting		slanting
203.0028 F	6040	20	150	23,5	8	35	3	16	11	7	7,5	203.0028 FX	6,4	203.0028 FXX
203.0027 F	6040	20	100	23,5	8	35	3	16	11	7	7,5	203.0027 FX	6,4	203.0027 FXX
203.0122 F	6050	25	200	35	20	55	4	25	18	11	12	203.0122 FX	10	203.0122 FXX
203.0423 F	6050	25	150	35	20	55	4	25	18	11	12	203.0423 FX	10	203.0423 FXX

Racks

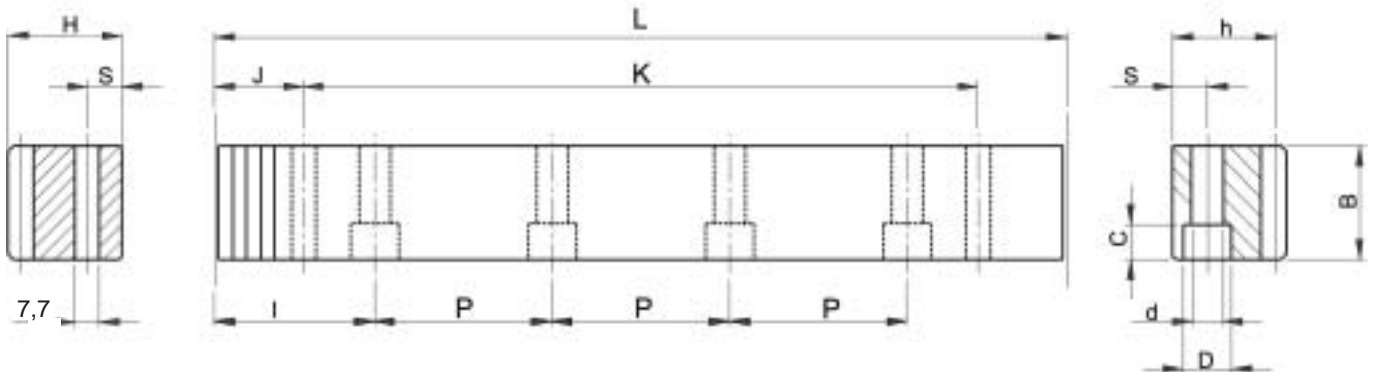

Straight t.	Code	ID	Mod.	Length	I	J	B#	d	D	S	h	H#	P	K	C
25x25#	211.2422	*	2	1005,3	62,8	31,3	24	7	11	8	22	24	125,66	942,7	7
30x30#	211.2351	*	3	1017,9	63,6	34,4	29	10	15	9	26	29	127,23	949,1	9
40x40#	211.2349	*	4	1005,3	62,8	37,5	39	10	15	12	35	39	125,66	930,3	9

Section for ID: BD – TD

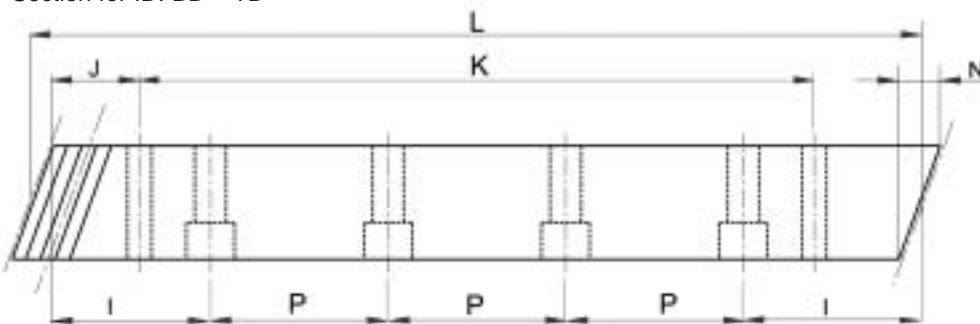

ID*	Description
BD	milled straight teeth
KBD	straight teeth
TD	hard.straight teeth
KTD	hard.straight teeth
KRD	hard. ground straight teeth
KBX	helical teeth
KTX	helical teeth
KRX	hard. ground helical teeth

Helical t.	Code	ID	Mod.	Length	I	J	B	d	D	S	h	H	P	K	N	C
25x25	211.2423	*	2	1000	62,5	31,7	24	7	11	8	22	24	125	936,6	8,5	7
30x30	211.2424	*	3	1000	62,5	35,0	29	10	15	9	26	29	125	930,0	10,3	9
40x40	211.2425	*	4	1000	62,5	33,3	39	10	15	12	35	39	125	933,4	13,8	9

Toothed pinions and cam-holding linear guides

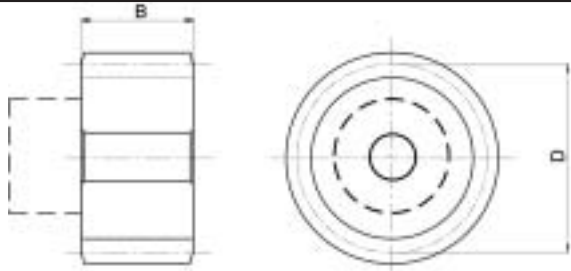

Suggested sizes			
D	44	63	68
B	20/28	30	40
Mod.	2	3	4
Teeth	22	21	17

Material: hardened and case-hardened steel. Usually supplied with flange shaft and bearing. Pinions are coupled with the chosen rack.

Microswitch cams

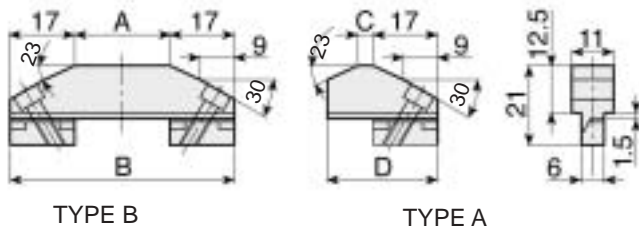

Code type B	A	B	Code type A	C	D
211.2132	25	59	211.2128	0	25
211.2133	40	74	211.2129	4	29
211.2134	63	97	211.2130	10	35
# 211.2135	80	114	211.2131	16	41
211.2136	100	134			

Material: steel with hard and ground surface

Cams complying with DIN 69639

Cams not complying with DIN 69639



Cam-holdus

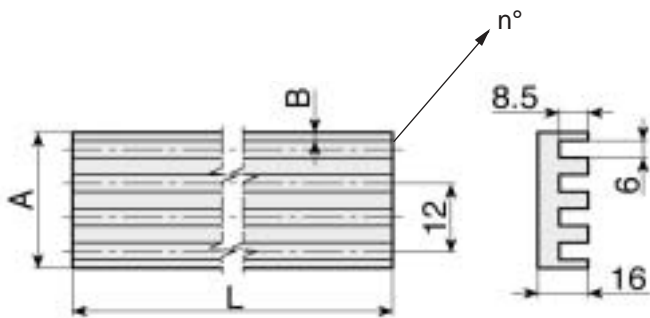

Code	n°	B	A	L
202.2138	3	3	36	2000
202.2139	4	5.5	53	3000
202.2140	6	5.5	77	3000
202.2141	8	5.5	101	3000

Complying with DIN 69638 –Material used: steel alloy

Roller slide spare part: + Ø 40-52-62 roller

Warning: Check that all devices are blocked properly, respecting the prescribed tightening torques.

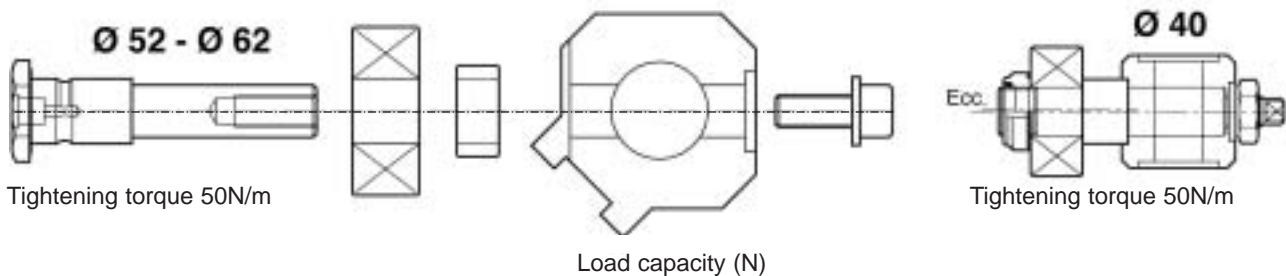

Roller	Cw	Cow	Fr amm.	max.speed	Code
Ø 40 Concentric	9800	6200	3500	7 m/s	205.0464
Ø 40 Eccentric	"	"	"	"	205.0463
Ø 52 Concentric	15800	10500	5000	6 m/s	205.0163
Ø 52 Eccentric	"	"	"	"	205.1416
Ø 62 Concentric	21100	14500	5000	5 m/s	205.0165
Ø 62 Eccentric	"	"	"	"	205.1417

